

THE CORPORATION OF THE TOWNSHIP OF NORTH GLENGARRY
Committee of the Whole

Wednesday, March 20, 2024, 3:00 pm

Council Chamber

3720 County Road 34

Alexandria, On. K0C 1A0

1. **CALL TO ORDER**
2. **DECLARATION OF PECUNIARY INTEREST**
3. **ACCEPT THE AGENDA(Additions/Deletions)**
4. **DELEGATIONS**
5. **STAFF REPORTS**
 - a. Building/Planning & By-law Department
 1. New Steel Roof for Township Office (3720 County Road 34)
 - b. Community Services Department
 1. Draft Parks and Recreation Action Plan
 2. Ice Resurfacers for Maxville
 - c. Treasury Department
 1. 2023 Reserve Update
 - d. Public Works Department
 1. Public Works Work Plan
 - e. Fire Department
 1. 2023 Fire Department Annual Report
6. **CONSENT AGENDA**
7. **UNFINISHED BUSINESS**
8. **OTHER BUSINESS**
9. **MATTERS ARISING FROM STANDING COMMITTEES**
 - a. Raisin Region Conservation Authority update by Councillor Jacques Massie
 - b. Maxville Manor update by Councillor Gary Martin
 - c. Glengarry Pioneer Museum update by Councillor Gary Martin
 - d. Glengarry Archives update by Mayor Jamie MacDonald
 - e. Arts, Culture & Heritage update by Councillor Jeff Manley
 - f. County Council update by Deputy Mayor Carma Williams

- g. Friends of the Trails update by Councillor Jeff Manley
- h. Community Development Committee by update by Mayor Jamie MacDonald
- i. Rural Affairs update by Councillor Jacques Massie

10. NOTICE OF MOTION

Next Committee of the Whole Meeting

Wednesday June 19th 2024 at 3:00 p.m. in the Council Chambers, 3720 County Road 34, Alexandria, Ontario.

Note: Meeting are subject to change or cancellation.

11. ADJOURNMENT



STAFF REPORT TO THE COMMITTEE OF THE WHOLE

Report No: BP-2024-07

March 20, 2024

From: Jacob Rheume, Director of Building, By-law & Planning Department

RE: **New Steel Roof for Township Office (3720 County Road 34)**

Recommended Motion:

THAT the Committee of the Whole approves staff recommendation of the proposal for the Township office roof to be re-done with steel roofing finish.

Background / Analysis:

During budget discussions for 2024, it was determined that the new Township office roof, located at 3720 County Road 34, Alexandria, had to be redone due to age, and because of leaks that happened in recent years. The previous owner, Glengarry Mutual Insurance Company had the building constructed in 2007 and the current asphalt shingle roof is the original roof that was installed in 2008 (approx.). On average, an asphalt roof lasts around 15-20 years and this roof has lasted approximately 16 years. However, the type of shingle, exposure to sun, roof slopes, and architecture of the roof all factor in to how long a specific asphalt roof lasts. In this case, the slope is low and there is a lot of sun exposure. These factors most likely accelerated the deterioration of the asphalt shingles and reduced the overall lifespan of the roof.

Based on quotes received in 2023, an amount of \$120,000 was approved by Council to replace the roof. During the budget meeting, Council also chose to change from shingles to typical steel roof (not a steel shingle roof) as the preferred option due to the projected lifespan of the product.

Township staff received two updated quotes from contractors for a steel roof. Staff requested that both the 4 "maximum vents" be replaced with new ones and all the ridge venting remain for proper venting of the attic to prevent the steel from overheating which would reduce the lifespan of the steel. Staff also requested that the existing shingles be removed and disposed of. The steel will be screwed directly into the sheeting "aspenite" as per manufacturer's recommendations.

The biggest concern with steel during winter months is the accumulation of snow that can fall from the roof and potentially injure someone or damage something, such as a vehicle. Due to the risk with staff and residents attending the building, staff have had discussions with both contractors, and it was determined that the “Ideal Guard 2-hole rod” system was the best solution to prevent this type of issue.

Attached is the spec sheet for the system, manufactured by the same company as the roof steel. The color of the bracket and rods would match the roof. These would be installed all around the building, on both sides of the front gable roof, except around the mechanical space as there is not much room there for snow accumulation.

Underlayment as per manufacturer’s recommendations, flashings, hip flashings, ridge vents, ridge flashing, screws, etc. are all included in both estimates. Workmanship for both contractors has been vetted by Township staff; both are excellent options. There were initially three contractors interested in performing the work, however only two submitted quotes.

Council and/or staff will need to determine the color, but this will have no to minimal impact on the cost as the majority of colors are the same price. Both contractors provided quotes for Americana 29gg steel. This is the most common steel used for roofing as the manufacturer makes it at 29gg as compared to 30 for most of the other roof sheeting, so it’s “stronger” than most other profiles.

Contractor	Price including material, labor, and HST
Van den Oetelaar Roofing & Contracting Inc.	\$84,234.76
Nic Brabant Renovation	\$73,337.00

The following are pictures of what a 2-pole snow guard looks like on other buildings.







Alternatives:

Option #1 That Council approves staff recommendation of the proposal for the Township office roof to be re-done with steel roofing finish and select the winning contractor. (Recommended)

OR

Option #2 Council does not approve staff recommendation. (Not Recommended)

Financial Implications:

Council approved \$120,000 towards a new roof for the Township office as part of the 2024 capital budget. Both quotes received are under budget.

Attachments & Relevant Legislation:

- Ideal Roofing Specs for Steel, Colours and Profile.

Others Consulted:

Sarah Huskinson, CAO/Clerk

Reviewed and Approved by:
Sarah Huskinson, CAO/Clerk



ideal roofing
Company Limited, Manufacturers
idéal revêtement
Compagnie Limitée, Manufacturiers

1418, rue Michael St., Ottawa, Ont. Canada K1B 3R2



& CANADIANA

Colours: Pre-Painted Steel • Couleurs: Acier Pré-Peint

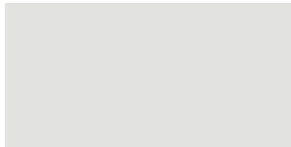

Polar White / Blanc Polaire ID 8783



White / Blanc ID 8317



Bone White / Blanc Os ID 8273



Stone Grey / Gris Pierre ID 8305



Regent Grey / Gris Régent ID 8730



Charcoal / Fusain ID 8306



Deep Grey / Gris Charbon ID 8314

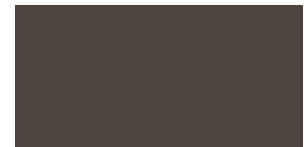

Coffee / Café ID 8326



Dark Brown / Brun Foncé ID 8229

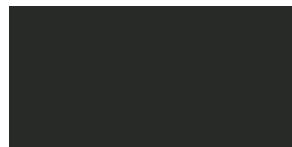

Black / Noir ID 8262



Classic Copper / Cuivre Classique ID 9919



Bright Red / Rouge Vif ID 8386

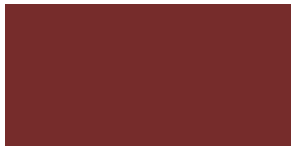

Red / Rouge ID 8250

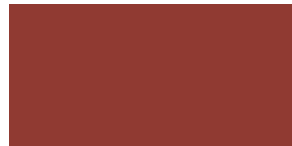

Tile Red / Rouge Tuile ID 8259

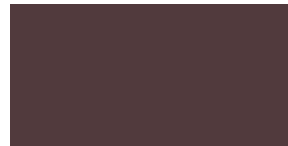

Burgundy / Bourgogne ID 8011



Antique Linen / Lin Antique ID 8696



Tan / Beige ID 8315



Pebble Khaki / Galet Kaki ID 8129



Slate Blue / Bleu Ardoise ID 8260



Royal Blue / Bleu Royal ID 8790



Heron Blue / Bleu Héron ID 8330



Medium Green / Vert Moyen ID 8329



Forest Green / Vert Forêt ID 8307

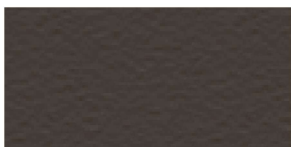

Sepia Brown / Brun Sépia ID 60041

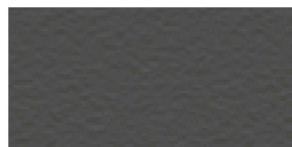

Graphite Grey / Gris Graphite ID 60035

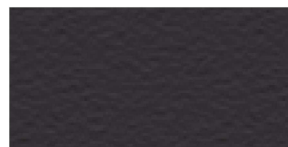

Jet Black / Noir De Jais ID 60039

Tel. 613-746-3206
Fax. 613-746-0445
1-800-267-0860
www.idealroofing.com

Printed in USA October 2023

PERSPECTRA PLUS SERIES™



SHERWIN-WILLIAMS
Coil Coatings

Sherwin-Williams® and WeatherXL™ are trademarks of SWIMC LLC.

FLASHINGS, TRIMS, FASTENERS AND ACCESSORIES

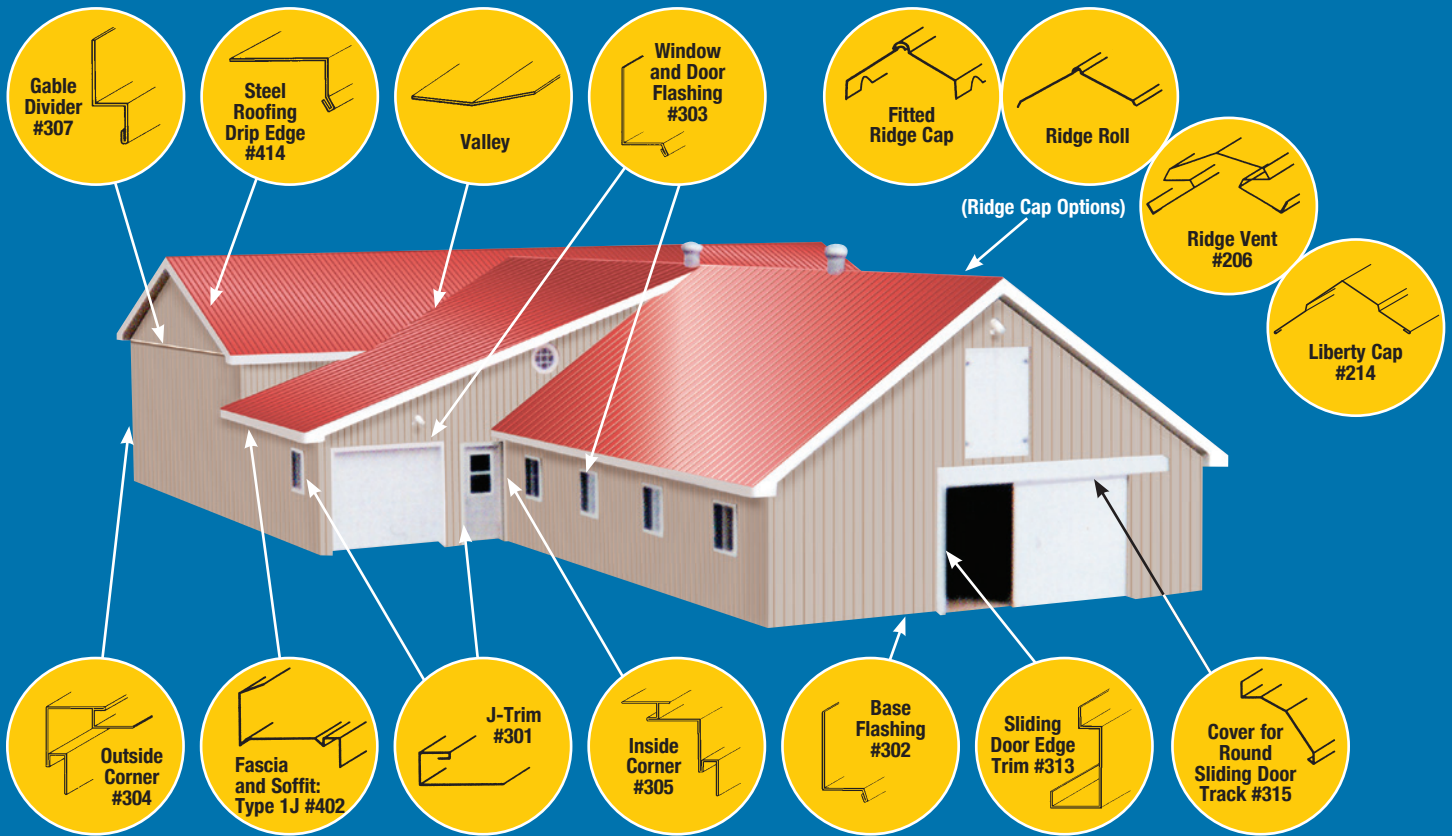

Ideal Guard	Ridge Roll, 10' lengths	Valley 18", 24", 36"	Closure Strip Eave Ridge	Ridge Vent, 10' lengths	Fitted Ridge Cap, 6' lengths	Roll Valley Coils, 50' lengths	SNOW DIAMOND
Fitted Wall Flashing	"Z" Bar	"U" Channel	Omega Bar	Touch-up paint	Screw with neoprene washer	#14 Self-drilling screw with 7/16" nylon head	#12-#14 Self-drilling screw with neoprene washer

To add the finishing touch, Ideal Roofing fabricates all its flashing and trims in all colors and materials.

UL 580 (Class 90), Wind Uplift Resistance (check our website for installation details).



Head Office
1418 Michael Street
Ottawa, Ontario, Canada K1B 3R2
www.idealroofing.com

Tel.: 613.746.3206
Toll Free: 1.800.267.0860
Fax: 613.746.0445
info@idealroofing.ca



Canadian Sheet Steel Building Institute
A Division of the Canadian Institute of Steel Construction



AMERI- CANA™

& CANADIANA

ROOFING AND SIDING PANELS



ideal roofing
Company Limited, Manufacturers

SOLID STEEL STRENGTH



U.S. EDITION

AMERI-CANA™ PANEL

SUPERIOR STRENGTH AND VERSATILITY

Ideal Roofing's Ameri-Cana roofing and siding panel offers superior strength with its strong **80,000 psi full-hard steel core** and its 5 specially-designed 3/4"-high ribs spaced every 9 inches. Superior strength means savings on wood or steel purlins for the builder. Please consult the following load tables.

"OUR RIBS ARE BETTER!"

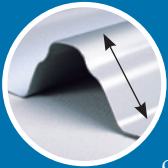

The ribs on the Ameri-Cana panel are reinforced to better accommodate fasteners. With its symmetrical pattern and ribs with steeper angles, the Ameri-Cana panel is considered the ultimate roofing or siding panel for agricultural, commercial or industrial buildings as well as for residential roofing applications.

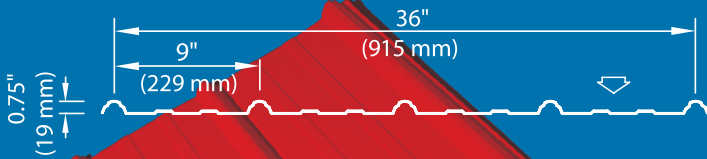

WEATHERTIGHT OVERLAP

Ideal Roofing's Ameri-Cana panel offers maximum protection against leakage with its built-in anti-siphon groove to counter water infiltration resulting from capillary action. This feature makes the Ameri-Cana panel "ideal" for use as a roofing sheet for long and low rafters with a roof pitch as low as 3/12.

UNIFORMLY DISTRIBUTED LOADS (LBS/FT²) FOR TRIPLE SPAN CONDITION

(Tested Under ASTM E72-05)

	18"	24"	30"	36"	42"	48"
29 gauge (.016")	304	171	95	67	49	38
26 gauge (.021")	423	237	135	87	63	48

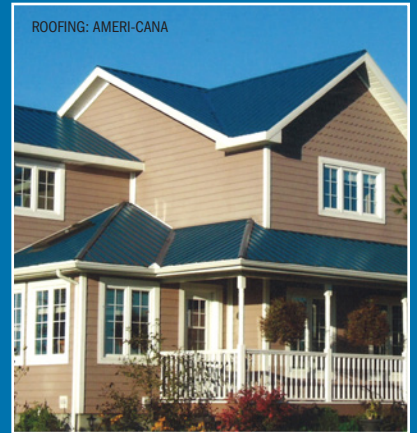
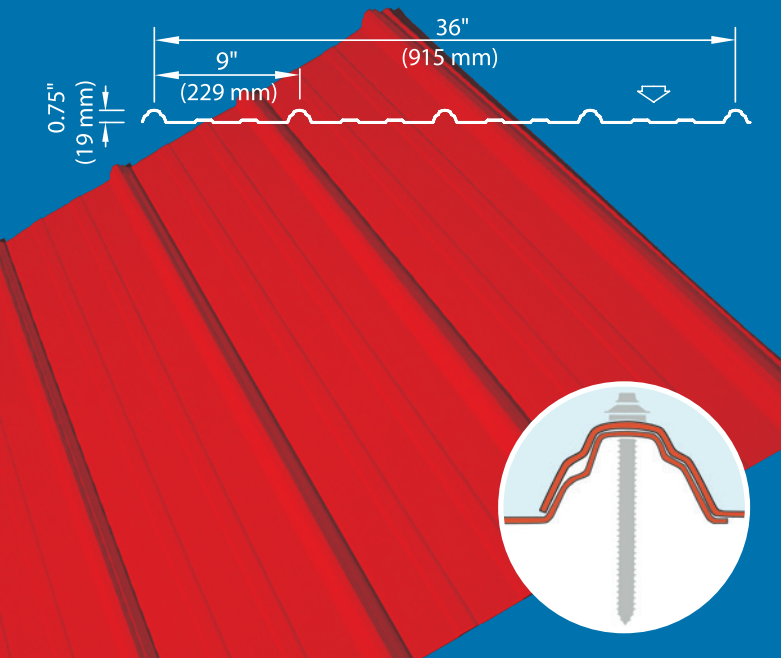

4 COATS OF PROTECTION FOR LONGER LIFE

- 1 ALUMINUM-ZINC ALLOY (GALVALUME AZ50)
- 2 METAL OXIDE PRETREATMENT
- 3 HIGH PERFORMANCE PRIMER
- 4 PERSPECTRA PLUS SERIES™ / WEATHER XL™

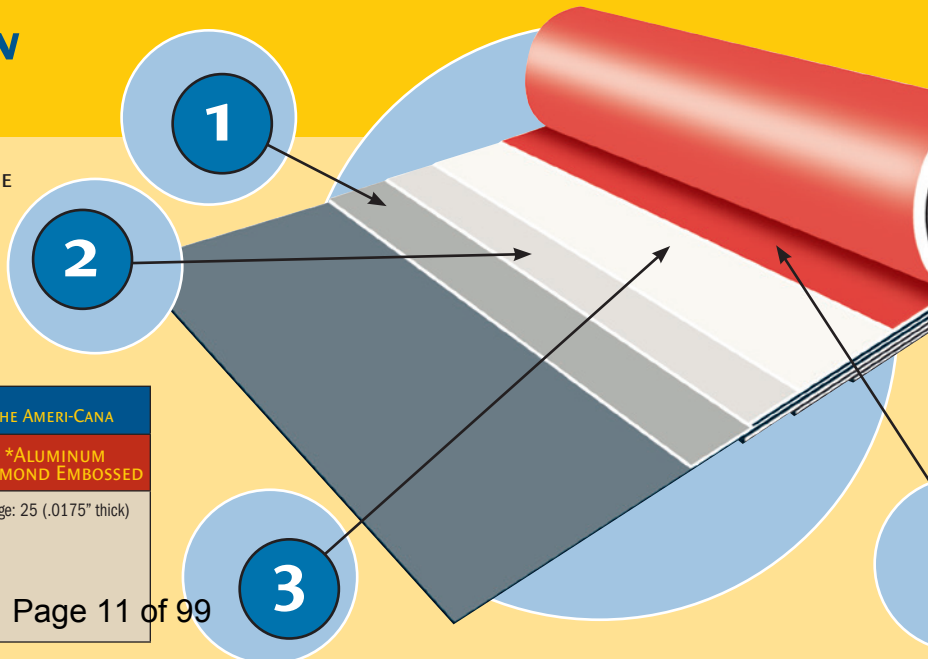

40 YEAR LIMITED WARRANTY

YOUR CHOICE OF MATERIAL *APPLICABLE ONLY ON THE AMERI-CANA			
GALVANIZED STEEL (MILL FINISH)	GALVALUME PLUS (MILL FINISH)	PRE-PAINTED GALVALUME STEEL	*ALUMINUM DIAMOND EMBOSSED
ASTM-A653 SS Grade 80, Z275 (G-90); Gauges: 29 (.016" thick) and 26 (.021" thick)	ASTM-A792 SS Grade 80, AZ55; Gauge: 29 (.016" thick)	Perspectra PLUS Series™ / Weather XL™: see color chart; ASTM-A792 SS Grade 80, AZ50; Gauges: 29 (.016" thick) and 26 (.021" thick)	Gauge: 25 (.0175" thick)

CANADIANA SIDING PANEL

SUPERIOR STRENGTH STEEL SIDING

The Canadiana panel is destined to become the industry's most versatile lightweight steel siding panel with its strong full-hard steel core 80,000 psi and its seven 5/8"-high ribs spaced every 6 inches.

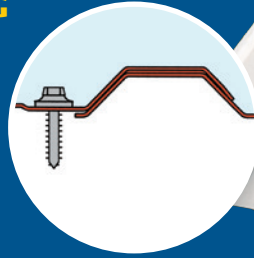

"... COVERS A WIDER AREA"

Economically formed from a 41-in.-wide steel coil to a final 36-in. ribbed sheet, this panel covers a wider area than other siding panels. Consider the aesthetic and structural qualities of our Canadiana steel siding panel for exterior and interior use on agricultural, commercial and industrial buildings.

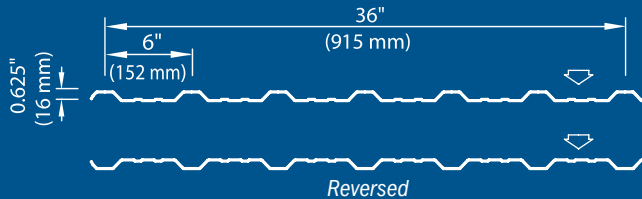

UNIFORMLY DISTRIBUTED LOADS (LBS/FT²) FOR TRIPLE SPAN CONDITION

(Theoretical Data)

	18"	24"	30"	36"	42"	48"
29 gauge (.016")	213	120	77	53	36	24
26 gauge (.021")	321	180	115	80	51	34

Normal Occupancy

	18"	24"	30"	36"	42"	48"
29 gauge (.016")	266	150	97	66	45	30
26 gauge (.021")	401	225	144	100	64	43

Low Human Occupancy (Farm Buildings)



TIME AND MONEY SAVERS

Both the Ameri-Cana and Canadiana panels save you time and money! Time because you install wider sheets covering 36-inches that are custom-cut to the inch in lengths measuring up to 40 feet, for your convenience. You save money because the Ameri-Cana and Canadiana panels are made from a 41-in.-wide flat steel sheet with considerably less metal waste than any other high-rib profile.

24 ATTRACTIVE COLORS TO ENHANCE YOUR BUILDINGS

Colors not exactly as shown. See color card.

 Dark Brown ID 8229	 Forest Green ID 8307	 Slate Blue ID 8260	 Regent Grey ID 8730	 Antique Linen ID 8696	 Pebble Khaki ID 8129
 Heron Blue ID 8330	 Tile Red ID 8259	 Charcoal ID 8306	 Royal Blue ID 8790	 Bright Red ID 8386	 Graphite Grey ID 60035
 Tan ID 8315	 White ID 8317	 Burgundy ID 8011	 Coffee ID 8326	 Medium Green ID 8329	 Jet Black ID 60039
 Red ID 8250	 Stone Grey ID 8305	 Bone White ID 8273	 Polar White ID 8783	 Black ID 8262	 Sepia Brown ID 60041

The “**Ideal Guard**” helps protect against falling ice and snow. It can be installed on any type of roof (metal, asphalt shingles, slate and cedar shakes.)

Components

Bracket: 1/8” (3.2mm) thick galvanized G-90 steel with 1¼” (32mm) diameter holes inserted with a plastic grommet. Each **bracket** includes #14x2 HHA screws with neoprene washers.

Tube: 1/16” (1.5mm) thick galvanized G-90 steel, 1” (25.4mm) diameter by 4’ (1.21m) long with an insert tip of 3” (75mm) therefor; 45” (1.14m) usable length.

Availability

Available in galvanized finish and all standard colors.

Installation

Anchoring the “**Ideal Guard**” brackets is essential to the performance of the system. Snow and ice exert pressure on the screws thus, the need to have a very solid substrate is important. The spacing of the brackets should not exceed 24” O.C.



**AVAILABLE BRACKETS:
1, 2 OR 3 HOLE**

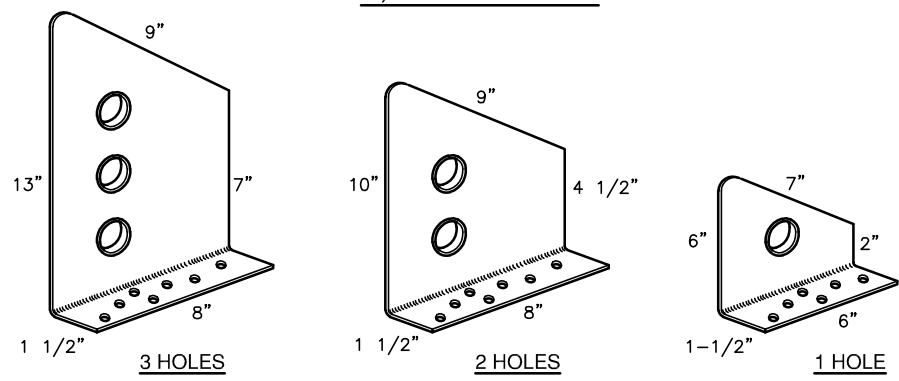

**"IDEAL GUARD"
ROD SPACING**

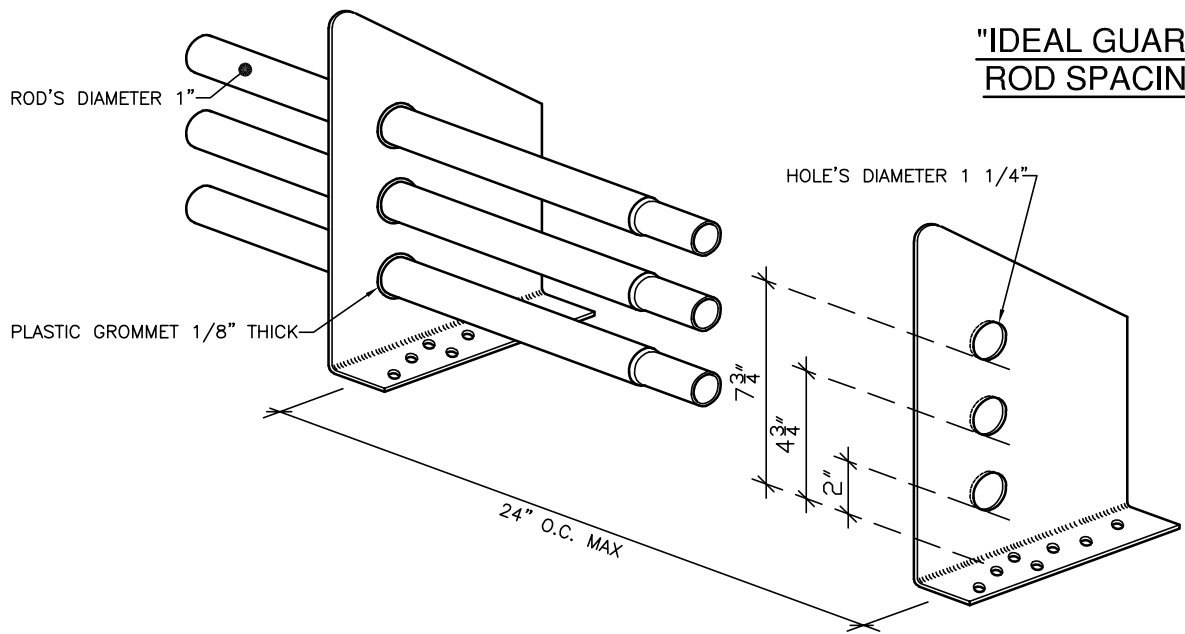

**"IDEAL GUARD"
TYPICAL INSTALLATION
(FASTENED TO WOOD)**

NOTE:
IN THE CASE OF A ROOF WITH A STEEL STRUCTURE, CONSULT A STRUCTURAL ENGINEER FOR THE PROPER INSTALLATION METHOD.

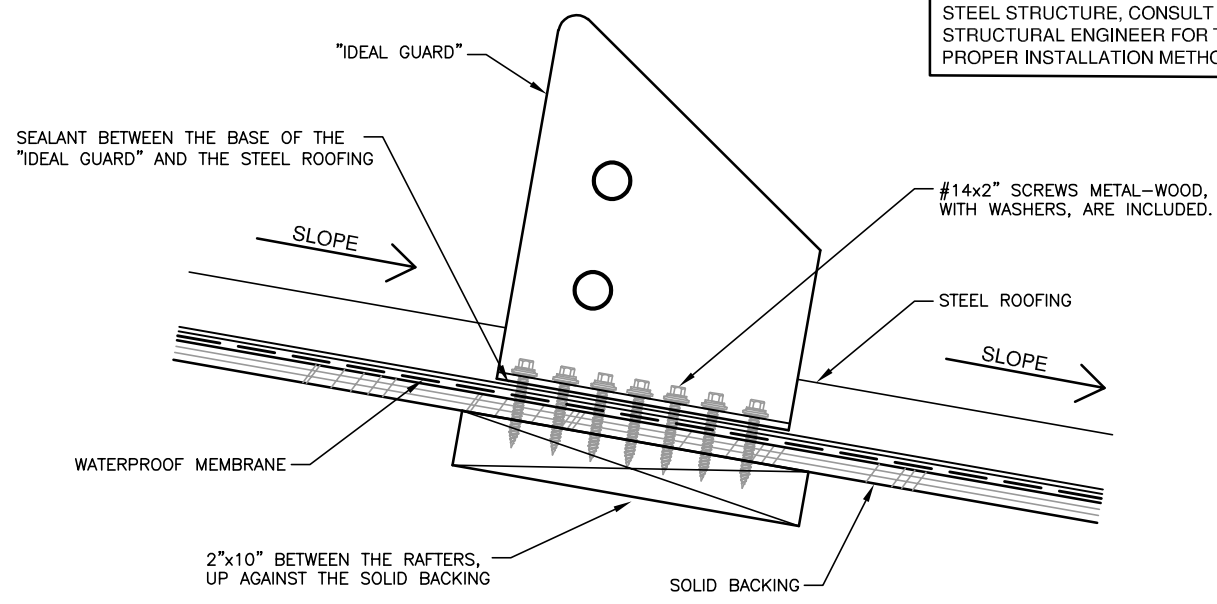

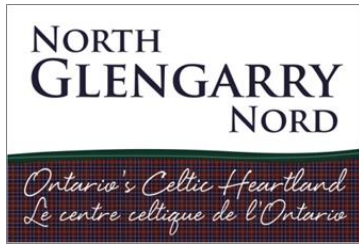

**STAFF REPORT TO THE
COMMITTEE OF THE WHOLE**

Report No: CS-2024-11

March 20, 2024

From: Anne Leduc – Director of Community Services

RE: Draft Parks and Recreation Action Plan

Recommended Motion:

THAT the Committee of the Whole receives Staff Report CS-2024-11 for discussion purposes.

Background / Analysis:

In 2023, Council mandated staff through its Corporate Strategic Plan to prepare a Parks and Recreation Action Plan. The Community was surveyed in the late summer and early fall of 2023. The data was collected as part of Appendix A to the Draft Parks and Recreation Action Plan.

Staff proposes that the Draft Parks and Recreation Action Plan be posted to the Township's website and circulated to community stakeholders for comments and feedback.

This information would then be incorporated in the draft and resubmitted to Council for a final review prior to being brought forward to Council for adoption.

Alternatives:

Option 1 – That Council approves the posting of the Draft Parks and Recreation Action Plan to the Township's website and that it be circulated to community stakeholders for comments and feedback.

Financial Implications:

None

Attachments & Relevant Legislation:

Attached - Draft Parks and Recreation Action Plan

Others Consulted:

Reviewed and Approved by:
Sarah Huskinson, CAO/Clerk

NORTH GLENGARRY NORD

*Ontario's Celtic Heartland
Le centre celtique de l'Ontario*



Parks and Recreation Action Plan

Township of North Glengarry

March 2024

DRAFT

For an alternate format of this document, please contact us at 613-525-1110 or by email at info@northglengarry.ca

Contents

Introduction	3
Demographics at a Glance	5
Action Plan.....	6
Summary of Survey Results*	9
Community Profile	9
Participation in Programming, Municipal and Community Events	10
Top Activities & Facility Usage	11
Reasons people use recreational activities outside North Glengarry	14
Programming Opportunities	15
Improvements to Parks, Facilities & Trails.....	16
APPENDIX A – SURVEY RESULTS.....	20
COMMUNITY PROFILE.....	20
PARTICIPATION IN PROGRAMMING, MUNICIPAL AND COMMUNITY EVENTS.....	23
NEED FOR IMPROVEMENTS TO FACILITIES, PARKS AND TRAILS	36
USE OF RECREATION SERVICES IN SURROUNDING COMMUNITIES	41
RECREATION PROGRAM/ACTIVITY, FACILITY AND PARKS NEEDS	45

***Sports serve society by providing vivid
examples of excellence.”***

George F. Will

Introduction

Township of North Glengarry Parks and Recreation Action Plan

The Township of North Glengarry's Parks and Recreation Action Plan identifies three pillars with corresponding actionables from now until 2027.

Pillars



Grow Recreation Capacity

- To increase sustainable programming in response to current demands and trends.



Foster Community Partnerships

- To support physical and social environments that build strong, caring communities.



Champion Active Living, Inclusion and Accessibility

- To increase access to recreation opportunities for all residents.

The actionables under each pillar were derived from the Parks and Recreation Action Plan survey community responses, the 2023 Corporate Strategic Plan adopted by Council in March 2023, and today's economic reality.

The Action Plan sets priorities for the Township to provide:

- Welcoming, accessible, and safe environments for everyone
- Opportunities for healthy and active lifestyles
- Quality customer experiences
- Diverse, inclusive, and affordable programming
- An environment that promotes community engagement and collaboration

Staff will report back to Council annually on the Action Plan and the Performance Indicators.

Guiding Framework

The Corporate Strategic Plan for the Township of North Glengarry identifies key pillars for the current term of Council – Grow, Foster and Champion. To ensure that the Parks and Recreation Action Plan is aligned with the community needs, input was received from the public and stakeholders, and research was performed into service gaps and trends.

The following tools were used during the process:

- Parks and Recreation Survey
- Framework for Recreation in Canada
- Building Condition Assessments for the Township’s facilities

Impacts on Action Plan



Over the years, the Township has strived to maintain a balance between its financial and recreational objectives, while providing programming that responds to its users. It is clear that balancing the needs of the community with today’s financial realities and aging infrastructure will be of paramount importance to successfully implementing the goals of the action plan.

From the responses received through the survey, the priority is on maintaining existing facilities, increasing access to programming, and removing financial barriers to participation in existing programs and services. There were several comments about the lack of access to a pool, the need for swimming lessons, and improvements and the addition of lights to fields.

Community partnerships have always been an important component in North Glengarry that allows for a broader range of services for the community. It is foreseeable that there will need for an increased focus on partnerships to grow programming and services.

Population trends impact both revenues and participation in programming. They will serve as indicators for the amount and types of services that should be provided.

Demographics at a Glance¹

Population

In 2021, the Canadian Census Profile reported that the Township of North Glengarry had 10,144 residents, which is a slight increase of 0.3% when compared to 2016. The population is forecasted to remain stable between now and 2026.

Income



In 2021, the average total income per individual in North Glengarry was

\$44,720

Age

The average age of the population has increased in 2021 to 47.3 years old from 46.5 in 2016. The trend towards an aging population is consistent with information from previous census data.

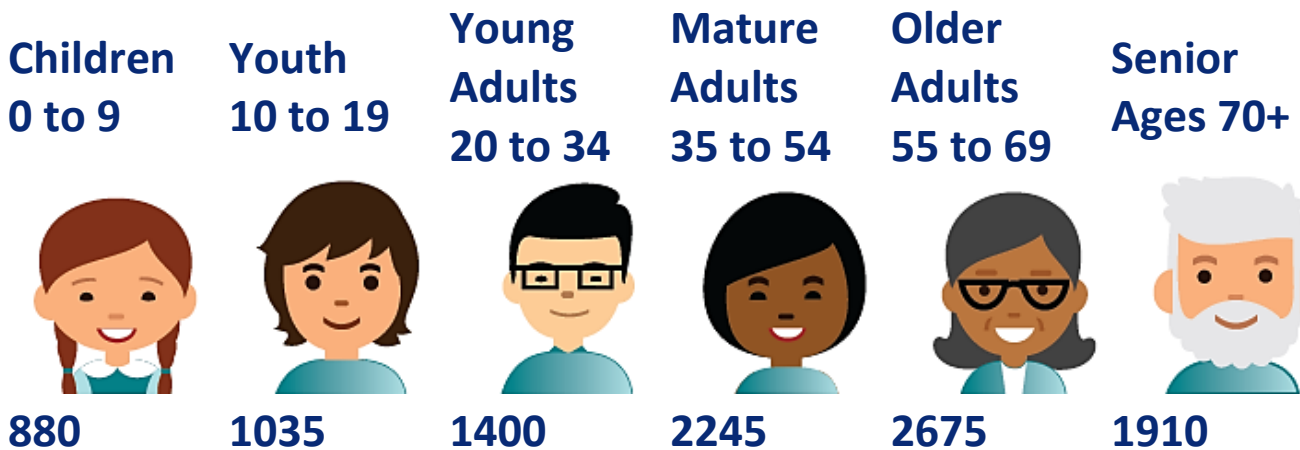

¹ Census Profile, 2021 Census of Population North Glengarry - <https://www12.statcan.gc.ca/census-recensement/2021/dp-pd/prof/details/page.cfm?Lang=E&SearchText=North%20Glengarry&DGUIDlist=2021A00053501050&GENDERlist=1,2,3&STATISTIClist=1&HEADERlist=0>

Action Plan



Pillar 1 – GROW Recreation Capacity

- To increase sustainable programming in response to current demands and trends.

ACTIONS:

PERFORMANCE INDICATORS:

Programming:

- Monitor program trends and interests in the recreation and parks sector and adjust programming accordingly.
- Identify services offered by neighbouring communities and private providers to determine areas where program duplication can be avoided and where the Township may be able to fill program gaps.
- Optimize program offerings based on needs and satisfaction rates (e.g. adjusting program schedules to meet areas of greatest need).
- Test demand for innovative/alternative program choices (pilot programs), including within underused facilities, parks, or non-peak times.
-

- Customer Satisfaction Surveys
- Track program participation and fill rates
- Facility utilization data
- Facility foot traffic
- Analyze data for pilot programs

Facilities Improvements:

- Continue to implement Council priorities and asset management plan to guide short and long-term investments in facilities to ensure that recreation and parks infrastructure is maintained to the quality that residents expect and need.

- Proposed capital investments in recreation facilities are brought to Council for inclusion in budget
- Identify grant opportunities that align with priorities are brought to Council

Recreation Software:

- Expand on-line registration offerings.

- Number of programs added to software for on-line registration

Customer Satisfaction:

- Create positive and memorable user experiences.

- Survey program / facility users regularly for improvements and comments
- Customer Service Training for new staff and refreshers for existing staff



Pillar 2 – FOSTER Community Partnerships

- To support physical and social environments that build strong, caring communities.

ACTIONS:

PERFORMANCE INDICATORS:

Partnerships:

- Work collaboratively with support organizations to identify, attract, and intentionally include participants from populations facing constraints accessing recreation and parks services.
- Establish new or strengthen existing partnerships to share existing resources to reduce the financial risks for all partners.
- Identify programming gaps or existing opportunities that respond to underserved segments of the population.

- Canvas community partners regularly on opportunities to collaborate on programming or use of facilities.
- Collaborate on grant opportunities to support facilities / programming.
- Number of new programs of programs that were enlarged / modified to include underserved population.
- Number of new participants affiliated with community partners.
- Participation and renewals in programming.

Community:

- Focus on Community-building activities /events that promote partnerships within those communities.
- Support community-based activities – Community Breakfasts, Carnivals, Canada Day, etc.

- Extend activities such as Meet Me on Main Street to surrounding areas.
- Usage of municipal facilities at no cost for community activities.
- In-kind for Community Grants recipients.



Pillar 3 – CHAMPION Active Living, Inclusion and Accessibility

- To increase awareness and access to recreation opportunities for all residents.

ACTIONS:

PERFORMANCE INDICATORS:

Awareness:

- Ensure consistent and coordinated messaging.
- Use social media and apps to enhance the dissemination of programming to the public and partners.
- Connect with community organizations to share their information on programming and resources that are available throughout the Township.

- Number of web page visits / social media followers
- Number of positive social interactions
- Correlation between traffic and program registrations

Active Living:

- Explore Active Living Charter with Eastern Ontario Health Unit

- Create Active Living Charter for North Glengarry to promote a healthy and active community.
- Council adopts Active Living Charter

Inclusion and Accessibility

- Identify existing barriers to access/participation along with ways to remove them.
- Identify funding sources for participants (Jumpstart, etc.).
- Ensure that programming is promoted as inclusive for people of all abilities.

- Ensure programming cost remains accessible and affordable while being sustainable
- Number of subsidy recipients
- Population segments that access programs and services through the subsidy
- Number of new participants



Summary of Survey Results*

* Complete responses to the Survey can be found in the Appendix to this document.

Level of satisfaction

49% of respondents indicated that they were Very Satisfied or Satisfied parks and recreation opportunities. 25% of respondents indicated that they were neutral, and 17% indicated that they were not satisfied or not satisfied at all.

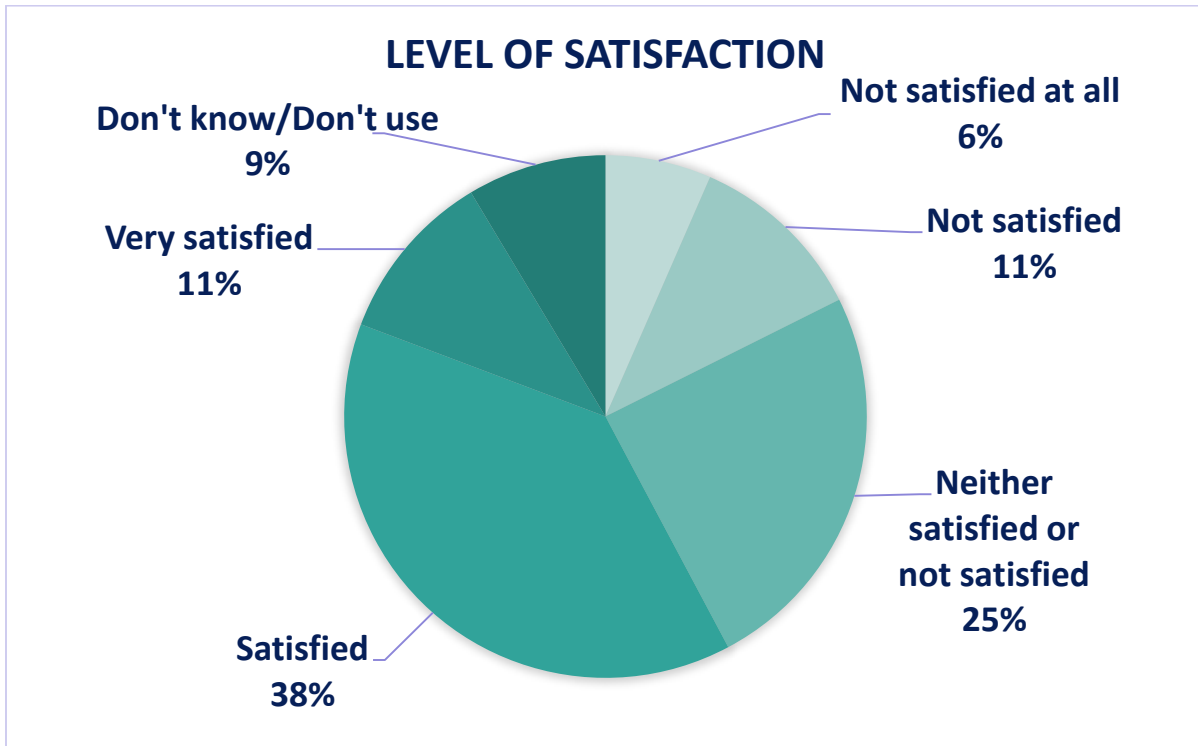

Community Profile

287 individual responses from persons living the following communities:

Township of North Glengarry	249
Township of South Glengarry	20
Township of Champlain	2
City of Cornwall	2
Municipality of Casselman	1
Town of Hawkesbury	0
<i>Other</i>	13
TOTAL	287

For North Glengarry, respondents indicated that:

- 131 lived in Alexandria
- 65 in Maxville
- 18 in Apple Hill
- 8 in Glen Robertson
- 7 in Dalkeith
- 7 in Dunvegan
- 6 in Lochiel
- 5 in Laggan
- 3 in Greenfield
- 2 in Glen Sandfield
- 1 in Dominionville

The top reasons people have moved to North Glengarry in recent years are:

- affordable residential real estate (21)
- desire for non-urban lifestyle (18)
- a good place to raise a family (18)
- lower cost of living (15)

They have lived in North Glengarry for:

Less than 1 year	2
1 to 5 years	33
6 to 10 years	26
11 to 15 years	17
15 to 20 years	27
More than 20 years	153
TOTAL	258

Households



- 124 couples with children
- 82 couples with dependent children
- 28 single adults
- 28 multiple adults sharing a residence
- 19 single parents with dependent children
- 6 multi-generational families
- 1 family with dependent child or adult

Participation in Programming, Municipal and Community Events

Participation Levels (Top Answers):

Recreation Program	Municipal Events	Community Events
Frequently (1/week or more):	Rarely (2-3 times per year)	Rarely (2-3 times per year):
<ul style="list-style-type: none"> ▪ Past 36 months - 128 ▪ Presently – 110 ▪ Within 24 months – 116 	<ul style="list-style-type: none"> ▪ Past 36 months - 97 ▪ Presently – 90 ▪ Within 24 months – 83 	<ul style="list-style-type: none"> ▪ Past 36 months - 84 ▪ Presently – 83 ▪ Within 24 months – 81

Present participation per age group

	Active Sport or Fitness	Non-sport	Both
Elementary School age 5 - 12 years	40	4	17
Adults 35 - 54 years	35	19	18
High School age 13 - 19 years	33	7	12
Older Adults 55 - 64 years	20	15	16
Young Adults 20 - 34 years	15	7	16
Seniors 65 - 74 years	11	9	11
Preschoolers 0-4 years	6	6	3
Seniors 75 years and older	1	5	2
TOTAL	161	72	95

Top Activities & Facility Usage

The following are some of the top activity requests that were identified during the consultation process.

Recreational Activities Top Ten responses:

Presently participating	
IN North Glengarry	OUTSIDE North Glengarry
56 - Walking outdoor	27 - Swimming (Recreational)
51 - Golf outdoor	26 - Walking outdoor
43 - Indoor Skating	25 - Skiing or Snowboarding
42 - Soccer outdoor	21 - Golf outdoor
40 - Hiking	21 - Hiking
36 - Cross-Country Skiing or Snowshoeing	16 - Weight Training
36 - Curling	15 - Playground equipment
35 - Playground equipment	13 - Boating (sailing, canoeing, powerboating, etc.)
33 - Dog Walking (on leash)	13 - Hockey (Youth)
31 - Cycling or Mountain Biking	13 - Swimming (instructional)

Within 24 months	
IN North Glengarry	OUTSIDE North Glengarry
25 - Swimming (Recreational)	23 - Hiking
23 - Walking outdoor	23 - Swimming (Recreational)
20 - Boating (sailing, canoeing, powerboating, etc.)	22 - Walking outdoor
20 - Weight Training	20 - Golf outdoor
19 - Hiking	16 - Cycling or Mountain Biking
19 - Swimming (instructional)	15 - Boating (sailing, canoeing, powerboating, etc.)
17 - Cycling or Mountain Biking	15 - Skiing or Snowboarding
17 - Golf outdoor	14 - Cross-Country Skiing or Snowshoeing
14 - Hockey (Youth)	14 - Swimming (instructional)
14 - Playground equipment	13 - Hockey (Youth)

Municipal Activities Responses:

Presently participating
IN North Glengarry
57 - Meet Me on Main Street
20 - December Holiday Public Skating, Parents & Tots, and Shinny Hockey
17 - Family Day
15 - Festival of Lights (in partnership with the Alexandria Lions Club)
8 - March Break Sports Camp (Dome)

2 - Kilt Skate

Within 24 months

IN North Glengarry

64 - Meet Me on Main Street
 62 - December Holiday Public Skating, Parents & Tots, and Shiny Hockey
 60 - Festival of Lights (in partnership with the Alexandria Lions Club)
 45 - Family Day
 19 - Kilt Skate
 18 - March Break Sports Camp (Dome)

Community Activities Responses:

Presently participating

IN North Glengarry

53	-	Glengarry Highland Games	10	-	CommUNITY Run
36	-	Alexandria Canada Day	9	-	Recreation Associations' Community Breakfasts
36	-	Maxville Fair	6	-	Dalkeith Carnival
34	-	Maxville Community Market	6	-	Glen Robertson Canada Day
31	-	Alexandria Santa Claus Parade	6	-	K9 Fest
28	-	Maxville Canada Day	6	-	Polar Bear Dip
25	-	Maxville Santa Claus Parade	5	-	Lobsterfest (Community Living Glengarry)
22	-	WOW (Glengarry Artists Collective	4	-	Community Bingo
19	-	Alexandria Remembrance Day	4	-	Summer Camp at Island Park
19	-	Grotto Music Series	3	-	Apple Hill Canada Day
17	-	Firefighters' Community Breakfasts	3	-	Light Up North Glengarry Contest
17	-	Women's Day	3	-	Youth Unlimited Summer Camp at Maxville & District Sports Complex
15	-	Alexandria "Baby Please Come Home" (Shop Local)	2	-	Apple Hill Remembrance Day
14	-	Maxville Tree Lighting	1	-	Jubilee (Fondation Hôpital Glengarry Memorial Hospital Foundation)
11	-	Alexandria Tree Lighting	1	-	Dalkeith Remembrance Day
11	-	Maxville Remembrance Day	1	-	Maxville Craft Fair
10	-	Alexandria Fishing Derby			

Within 24 months			
IN North Glengarry			
88	- Glengarry Highland Games	20	- Maxville Remembrance Day
73	- Alexandria Canada Day	18	- CommUNITY Run
68	- Alexandria Santa Claus Parade	18	- Dalkeith Carnival
47	- Grotto Music Series	16	- Polar Bear Dip
44	- Alexandria "Baby Please Come Home" (Shop Local)	15	- Alexandria Fishing Derby
44	- Maxville Community Market	15	- Light Up North Glengarry Contest
43	- Alexandria Tree Lighting	13	- WOW (Glengarry Artists Collective
43	- Maxville Fair	11	- Community Bingo
40	- Firefighters' Community Breakfasts	11	- Summer Camp at Island Park
39	- Women's Day	10	- Apple Hill Canada Day
38	- Maxville Santa Claus Parade	8	- Jubilee (Fondation Hôpital Glengarry Memorial Hospital Foundation)
35	- Alexandria Remembrance Day	7	- Glen Robertson Canada Day
34	- Maxville Canada Day	7	- Youth Unlimited Summer Camp at Maxville & District Sports Complex
24	- Recreation Associations' Community Breakfasts	5	- Apple Hill Remembrance Day
21	- Lobsterfest (Community Living Glengarry)	1	- Dalkeith Remembrance Day
21	- Maxville Tree Lighting	0	- Maxville Craft Fair
20	- K9 Fest		

Township Facilities Usage

Participants indicated which facilities they used:

49	- Island Park (Alexandria)
0	
29	- Maxville & District Sports Complex (Maxville)
3	
22	- Glengarry Sports Palace (Alexandria)
0	
12	- Tim Hortons Dome (Glengarry Indoor Sports Complex) (Alexandria)
5	
52	- Apple Blossom Park (Apple Hill)
41	- Father Gauthier (Lochiel)
40	- Centennial Park (Maxville)
37	- King George Park (Maxville)
37	- Laggan Public School (Laggan)
36	- Clark-MacIntosh Park (Dunvegan)

34 - Dalkeith
20 - Greenfield
19 - Glen Robertson

Activities in other facilities

The following are activities taking place in facilities IN North Glengarry not owned or operated by the Township.

5 - Golf	1 - Hiking
4 - Church worship service	1 - Hockey
4 - Reading newspapers/books	1 - Information
2 - Art shows	1 - Legion
2 - Glengarry Pioneer Museum	1 - Lions Club breakfasts
2 - Soccer	1 - Lochiel Centre
2 - Yoga	1 - Minor Hockey and Minor Baseball
1 - Canada Day festivities	1 - Paint Class
1 - Card games	1 - Performing Music & Mayhem shows
1 - Community Events	1 - Running
1 - Concerts	1 - Sand bag
1 - Crossfit	1 - Senior group exercise program
1 - Evening suppers	taking out books and using activities at the library
1 - Festivals	1 - Volleyball, Off Ice hockey training
1 - Fund raisers, rink,	1 - Walking at Maxville Fairgrounds

Reasons people use recreational activities outside North Glengarry

Responders advised that they participated in recreational outside North Glengarry because specific activities were not available in the Township (e.g., skiing, boating or swimming lessons). Others had activities planned alongside trips to shops. Some indicated that the facilities or programming were better at other locations or that their leagues operated outside North Glengarry. We note that several respondents indicated that they did not know what was available in North Glengarry.

The top activities accessed in other communities are:

14 - Soccer
12 - Hockey
11 - Walking / Hiking trails
10 - Pools for swimming and lessons

From the time the survey closed to when this report was finalized, the Hôpital Glengarry Memorial Hospital’s pool is now available for public swimming and the plan is to expand programming in the future.

Programming Opportunities

Active sport/fitness programming	
Water-Based Activities (e.g., Canoe, Kayak, Swimming, etc.)	61
Group Fitness Classes (e.g., Aerobics, Zumba, Yoga, etc.)	45
Court Sports (e.g., Tennis, Pickleball, Badminton, etc.)	37
Arena Ice Activities (e.g., Hockey, Figure Skating, Broomball, etc.)	30
Field Sports (e.g., Soccer, Lacrosse, Ultimate Frisbee, etc.)	27
Arena Non-ice Activities (e.g., Floor Hockey, Box Lacrosse, Roller Derby, etc.)	26
Martial Arts (e.g., Karate, Tae Kwon Do, Jiu Jitsu, MMA, etc.)	20
Gymnasium sports (e.g., Basketball, Volleyball, etc.)	19
Outdoor Ice Activities (e.g., Learn to Skate, Shiny, etc.)	19
Wheel Sports (e.g., BMX, Fat biking, Skateboarding, etc.)	15
None of the above	9
Other	18

From the table above, there are opportunities within the Township’s existing infrastructure to expand programming if not in all, then in most of the categories listed. The activities could be directly led by the Township or in partnership with community or private organizations.

Non-sport or recreational programming	
Wellness programs (e.g., Tai Chi, Mental Health, etc.)	47
Artisanal (e.g., Quilting, Handmade food, Sculpting, etc.)	41
Visual Arts (e.g., Painting, Photography, Digital Media, etc.)	38
Learning/Self-improvement (e.g., Local heritage, Nutrition, Computer, etc.)	34
Social/Club Activities (e.g., Youth Drop-ins, Seniors, New Parents, etc.)	33
Environmental (e.g., Pollinator Gardens, xeriscape gardening, etc.)	26
Performing Arts (e.g., Drama, Choral, etc.)	26
Seniors’ Programs	23
Camps (e.g., Day, Summer Break, Winter Break, etc.)	21
None of the above	17
Before and after school programs	14
Play programs for preschooler	13
Other	2

For non-sport or recreational programming opportunities, several community partners are already offering activities in most of these categories.

Glengarry Trails Usage

Walking or Dog Walking	126	Cross Country Skiing	18
Running	12	Cycling - Biking	20
Snowshoeing	38	Other	5

Activities listed under “Other” on the Glengarry Trails included ATVing, Geotagging, snowmobile, and swimming.

Improvements to Parks, Facilities & Trails

Participants indicated that improvements should be made to the following. Information has been added under the Status and Comment column:

#	IMPROVEMENT TO PARKS & FACILITIES	Status	Comment
52	Washrooms	Yearly improvements	Assume Island Park
47	More shade, seating, lighting, etc.	Yearly additions / Budget dependant	Assume Island Park
45	Improved access to beach / water for swimming, kayaking, canoeing, etc.	Yearly additions / Budget dependant	Assume Island Park
44	Arena repairs Maxville		
42	More water play features	Approved repairs 2024 Capital Budget	Island Park
40	Water fountains	2 to be installed in 2024 Paid for in partnership with Lions Club	GSP & Island Park
38	Better playing fields for soccer	Ongoing	Various fields across NG
36	Outdoor gym/fitness stations	2 double stations already installed	Island Park
35	Food gardens	Possibly 2024	Funding application – waiting on results
31	Increased maintenance/clean up	Ongoing	
30	More walking paths to within/parks		No location identified
27	Covered areas (gazebos)		No location identified
24	Multi-purpose play court		Maxville outdoor court + MSC + GSP arena in summer
20	Better playing fields for baseball/softball	Ongoing	GSP & MSC fields
15	New/improved play equipment	Continuous	Play equipment replaced in majority in 2018/2019
11	Arena repairs Alexandria	2022 Refurbishment	Grant application – waiting on results

8	Better playing fields for other turf sports	Sod fields already used for football/flag football	Sport not identified
7	AODA accessibility improvements	Continuous	
7	Concrete pads for wheel sports	Community project - expansion completed in 2023	Alexandria Skate park
25	<i>Other</i>		

Other:	Status	Comment
▪ Swimming Pool	Reopened Spring 2024	Partnership HGMH
▪ Bike paths/lanes, safe bike areas	Continuous	Included in PW road planning
▪ Lights for Maxville soccer field	Capital project	Funding or grant dependant
▪ Dog park		
▪ Splash pad for Maxville!!		
▪ Swimming Lessons at HGMH	Ongoing	Application for courses with Lifesaving Society
▪ Indoor pool and a outdoor pool for the ones who do not enjoy refreshing in the islands water.	Indoor pool available as of Spring 2024	
▪ Larger library spaces		Responsibility - SDG Libraries
▪ Maxville outdoor basketball court with lights	Project completed in Fall 2023	Maxville asphalt pad
▪ More garbage cans, picnic tables, better hours at library and public washrooms	Outdoor equipment added or repaired yearly	Library – responsibility SDG Libraries
▪ More shaded seating areas in Maxville		
▪ No improvements needed in Maxville. There is already too much focus on recreation and not enough on other civic matters and issues. Maxville		

would benefit greatly from more attention being paid to issues such as speeding on Main Street.		
<ul style="list-style-type: none"> Outdoor track. The track at Glengarry District High School is in rough shape. This is a space that is used by students as well as members of the community in the evenings, weekends, holidays, etc. 		Responsibility - UCDSB
<ul style="list-style-type: none"> Tennis court repair at the Dome 	Repairs & cracks filled Spring 2024	
<ul style="list-style-type: none"> Tennis courts 	Part of future Capital Budgets	Assume Island Park
<ul style="list-style-type: none"> The washrooms are not open all season near the play structures. As part of a large homeschooling community, this is not convenient. 	Bathrooms available from May to October	
<ul style="list-style-type: none"> Water Fountain at Maxville Soccer Fields 		

#	IMPROVEMENTS TO GLENGARRY TRAILS
40	Amenities along trail (e.g., washrooms, benches, picnic spots)
25	More/improved trail heads (e.g., parking, trail maps/details, washrooms)
22	Signage and wayfinding along trail
20	Better trail maintenance
11	More patrols/monitoring
7	Educational/stewardship initiatives
3	Better AODA accessible segments
4	Other

Trends show that walking is the activity with one of the highest participation rates, and other activities such as jogging and cycling continue to be some of the most popular and accessible activities.

The Glengarry Trails are a highly valued amenity in North Glengarry, which is not surprising given the trend toward individual, flexible, informal recreation. Overall, trails offer a great deal of value for a relatively low amount of investment and maintenance costs.

APPENDIX A – SURVEY RESULTS

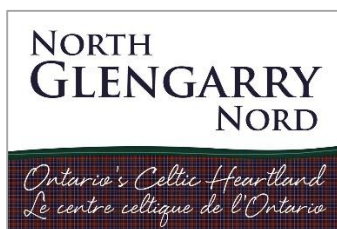

Township of North Glengarry

3720 County Road 34

R.R. 2

Alexandria ON K0C 1A0

Tel: 613-525-1110

www.northglengarry.ca

The Township of North Glengarry embarked on a public consultation regarding its Parks and Recreation Facilities in the Fall of 2023. The survey contained 38 questions with the majority offering multiple choice answers. In all, the Township received 287 individual responses.

COMMUNITY PROFILE

This group of questions helped to develop a group profile of respondents to the survey.

1. In which of the following municipalities do you live?

Township of North Glengarry / Canton de Glengarry nord	249
Township of South Glengarry / Canton de South Glengarry	20
Township of Champlain / Canton de Champlain	2
City of Cornwall / Ville de Cornwall	2
Municipality of Casselman / Municipalité de Casselman	1
Town of Hawkesbury / Ville de Hawkesbury	0
<i>Other</i>	13

TOTAL 287

Other

- Nation 2
- North Stormont 8
- Ottawa, ON 1
- South Stormont 2

2. Where do you live in the Township of North Glengarry?

Alexandria	131
Apple Hill	18
Dalkeith	7
Dominionville	1
Dunvegan	7
Glen Robertson	8

Glen Sandfield	2
Greenfield	3
Laggan	5
Lochiel	6
Maxville	65

TOTAL 253

3. How long have you had a residence in the Township of North Glengarry?

Less than 1 year / Moins d'un an	2
1 to 5 years / 1 à 5 ans	33
6 to 10 years / 6 à 10 ans	26
11 to 15 years / 11 à 15 ans	17
15 to 20 years / 15 à 20 ans	27
More than 20 years / Plus de 20 ans	153

TOTAL 258

4. If you have moved to North Glengarry within the last five years, indicate the reasons (select all that apply)

Affordable residential real estate	21
Desire for non-urban lifestyle	18
Good place to raise a family	18
Lower cost of living	15
Proximity to urban areas	8
Ability to work remotely regardless of location	5
Reasons related to COVID-19	5
Retirement	3
Converted seasonal to permanent dwelling	2
<i>Other</i>	13

108

Other

- 35 years 1
- Career advancement and moving closer to family 1
- Closer to family 7
- Help parents with their land 1

- Immigration 1
- Job in Montreal but still able to live in Ontario 1
- Took over family home / farm 2

5. Which of the following best describes your household?

Couple with dependent child(ren) / Couple avec enfant(s) à charge	124
Couple without dependent child(ren) / Couple sans enfant(s) à charge	82
One adult / Un adulte	28
More than one adult sharing a residence / Plus d'un adulte partageant une résidence	23
One parent with dependent child(ren) / Un parent avec enfant(s) à charge	19
Extended family (3+ generations) / Famille élargie (plus de 3 générations)	6
One parent with dependent child(ren) and one or more adults / Un parent avec enfant(s) à charge et un ou plusieurs adultes	5

TOTAL 287

6. How many people, including yourself, live in your household?

Two	89
Four	71
Three	49
Five	35
One	27
Six	11
Seven	4
Nine	1
Eight	0
10 or more	0

287

7. Please indicate the total number of persons within your household that fall into the following age categories.

35 - 54 years	258
55 - 69 years	174
10 - 19 years	173
20 - 34 years	115

5 - 9 years	86
4 years and under	52
70 years and over	44

TOTAL 902

PARTICIPATION IN PROGRAMMING, MUNICIPAL AND COMMUNITY EVENTS

8. How often did you or others in your household participate in recreation programming, municipal events, and community events in the Township of North Glengarry? Please consider both organized programs (e.g., Hockey or soccer leagues, yoga, dance, etc.) and unstructured activities (e.g., playground use, dog walking, observing nature, pleasure skating, etc.) (Select all that apply)

	Past 36 months	Presently	Within the next 24 months
Recreation Program			
Frequently (about 1/week or more)	128	110	116
Occasionally (about 1/month)	25	30	31
Rarely (2-3 times per year)	30	31	35
Never	21	32	22
Municipal Events			
Frequently (about 1/week or more)	39	30	30
Occasionally (about 1/month)	52	55	64
Rarely (2-3 times per year)	97	90	83
Never	16	28	26
Community Events			
Frequently (about 1/week or more)	37	37	36
Occasionally (about 1/month)	69	66	68
Rarely (2-3 times per year)	84	83	81
Never	14	17	18

9. Within the past 36 months, which of the following age groups in your household participated in active sport/fitness, non-sport recreation or both types of programs/activities in the Township of North Glengarry (Select all that apply)

	Active Sport or Fitness	Non-sport recreation	Both
Preschoolers 0-4 years	10	9	7
Elementary School age 5 - 12 years	34	6	20

High School age 13 - 19 years	32	9	15
Young Adults 20 - 34 years	18	10	9
Adults 35 - 54 years	38	26	19
Older Adults 55 - 64 years	20	16	15
Seniors 65 - 74 years	10	11	9
Seniors 75 years and older	0	6	2
	162	93	96

10. Presently which of the following age groups in your household participate in active sport/fitness, non-sport recreation or both types of programs/activities in the Township of North Glengarry (Select all that apply)

	Active Sport or Fitness	Non-sport recreation	Both
Preschoolers 0-4 years	6	6	3
Elementary School age 5 - 12 years	40	4	17
High School age 13 - 19 years	33	7	12
Young Adults 20 - 34 years	15	7	16
Adults 35 - 54 years	35	19	18
Older Adults 55 - 64 years	20	15	16
Seniors 65 - 74 years	11	9	11
Seniors 75 years and older	1	5	2
	161	72	95

11. Within the next 24 months which of the following age groups in your household will participate in active sport/fitness, non-sport recreation or both types of programs/activities in the Township of North Glengarry (Select all that apply)

	Active Sport or Fitness	Non-sport recreation	Both
Preschoolers 0-4 years	12	5	9
Elementary School age 5 - 12 years	38	3	21
High School age 13 - 19 years	30	7	14
Young Adults 20 - 34 years	16	9	15
Adults 35 - 54 years	40	20	23
Older Adults 55 - 64 years	22	11	20
Seniors 65 - 74 years	12	11	13
Seniors 75 years and older	3	5	3
	173	71	118

12. This question is to evaluate past, present and future participation in programming/activities. By participation, we mean situations where you or a member of your household actively participate (which does not include attending an event or watching others), either at home or in public. (Select all that may apply)

	Participated in the past 36 months		Presently participating		Plant to participate within 24 months	
	NG	Outside NG	NG	Outside NG	NG	Outside NG
Aerobics	14	10	10	2	10	5
Aquafit	3	1	8	10	12	12
Ball Hockey (Youth)	11	9	7	1	4	3
Ball Hockey (Adult)	9	14	7	1	0	4
Broomball	5	4	4	3	1	4
Baseball or Softball (or other forms) (Youth)	15	16	14	6	8	6
Baseball or Softball (or other forms) (Adult)	12	15	13	6	8	6
Basketball	9	8	6	1	2	5
Boating (sailing, canoeing, powerboating, etc.)	24	24	22	13	20	15
Cross-Country Skiing or Snowshoeing	31	15	36	10	3	14
Curling	41	23	36	4	2	4
Cycling or Mountain Biking	35	40	31	12	17	16
Dance Classes	15	13	16	2	6	6
Dog Walking (on leash)	39	67	33	9	12	10
Figure Skating	4	1	5	0	3	2
Flag Football Indoor	1	2	3	2	1	1
Football outdoor	2	4	3	0	1	1
Golf outdoor	57	48	51	21	17	20
Golf ball cage practice (indoors)	1	0	2	3	2	3
Gymnastics	1	0	3	2	10	5
Hiking	37	53	40	21	19	23
Hockey (Youth)	38	25	28	13	14	13
Hockey (Adult)	25	21	18	5	7	6

Horseback Ricking	9	5	8	5	5	2
Indoor Skating	50	25	43	11	9	12
Indoor Walking	23	13	25	4	3	2
Jazzercise	1	0	2	0	1	0
Lawn Bowling	0	1	2	0	1	0
Meditation	5	8	11	2	5	1
Organized Children's Programs (Summer Camp, After School drop- in, etc.)	15	13	17	3	4	4
Organized Seniors Programs (e.g. luncheons, cards, special interest courses, etc.)	7	12	11	2	2	1
Performing Arts (dance, music, theatre, etc.)	18	15	21	12	10	10
Pickleball	14	14	19	0	4	2
Parents & Tots Skating	10	7	9	0	1	0
Parents & Tots Playtime (Dome)	10	6	11	0	1	0
Playground equipment	38	53	35	15	14	12
Ringuette	0	0	1	0	1	0
Rugby	0	0	2	1	2	0
Running or jogging indoor	10	7	8	3	2	2
Running or jogging outdoor	25	28	23	5	6	4
Running program indoor	4	1	5	0	1	1
Seniors Educational Programming	7	7	10	0	2	0
Shinny Hockey	23	15	22	9	5	6
Skateboarding	7	7	10	2	3	1
Skating indoor	29	19	30	6	7	7
Skating outdoor	21	8	22	12	10	10
Skiing or Snowboarding	3	1	5	25	12	15
Soccer indoor	27	18	26	3	5	5
Soccer outdoor	47	71	42	7	11	8
Splash Pad	39	42	30	12	14	11
Squash or Racquetball	0	0	2	2	1	0
Swimming (Instructional)	2	4	8	13	19	14
Swimming (Recreational)	17	25	24	27	25	23
Tennis	11	12	15	7	4	5
Visual Arts (e.g., painting, sculpture)	8	8	15	7	1	3

Volleyball indoor	16	9	20	5	3	2
Volleyball outdoor	6	6	12	2	2	1
Walking indoor	14	12	18	2	2	2
Walking outdoor	60	88	56	26	23	22
Weight Training	17	25	26	16	20	13
Yoga	27	20	30	9	7	6
Zumba	8	2	6	3	3	1
<i>Other</i>	3	6	3	2	0	0
TOTAL: 4396 1060 1026 1081 407 430 392						

Other

- Broadsword
- Cooking class
- Fencing, ultimate frisbee
- Fitness classes
- Focus on Soccer
- Hunting/fishing
- I have rented Sandfield hall to lead senior fitness and yoga classes.
- Music and concerts
- Swimming in Cornwall
- Swimming lessons in Cornwall

13. This question is to evaluate past, present and future participation in municipal events. In this case participation means attending an event or watching others. (Select all that may apply)

	Participated in the past 36 months	Presently participating	Plan to participate within the next 24 months
December Holiday Public Skating, Parents & Tots, and Shiny Hockey	62	20	62
Family Day	55	17	45

Festival of Lights (in partnership with the Alexandria Lions Club)	79	15	60
Kilt Skate	15	2	19
March Break Sports Camp (Dome)	15	8	18
Meet Me on Main Street	2	57	64
<i>Other</i>	6	3	8
TOTAL	234	122	276

Other

- Ball hockey maybe, and senior adult hockey
- Canada Day
- Canada day parade, Christmas parade
- Highland games, canada day
- March break holiday skate and shinny
- Maxville Fair - Amazing Race
- Parents and tots dome
- Swimming Lessons
- We need lights for our soccer field

14. This question is to evaluate past, present, and future participation in community events. In this case participation means attending an event or watching others. (Select all that may apply)

	Participated in the past 36 months	Presently participating	Plan to participate within the next 24 months
Alexandria "Baby Please Come Home" (Shop Local)	37	15	44
Alexandria Canada Day	79	36	73
Alexandria Fishing Derby	7	10	15
Alexandria Remembrance Day	37	19	35
Alexandria Santa Claus Parade	75	31	68

Alexandria Tree Lighting	35	11	43
Apple Hill Canada Day	7	3	10
Apple Hill Remembrance Day	5	2	5
Community Bingo	7	4	11
CommUNITY Run	19	10	18
Dalkeith Carnival	20	6	18
Dalkeith Remembrance Day	1	0	1
Firefighters' Community Breakfasts	44	17	40
Glengarry Highland Games	96	53	88
Glen Robertson Canada Day	9	6	7
Grotto Music Series	46	19	47
Jubilee (Fondation Hôpital Glengarry Memorial Hospital Foundation)	9	1	8
K9 Fest	15	6	20
Light Up North Glengarry Contest	19	3	15
Lobsterfest (Community Living Glengarry)	12	5	21
Maxville Canada Day	48	28	34
Maxville Community Market	50	34	44
Maxville Craft Fair	0	0	0
Maxville Fair	56	36	43
Maxville Remembrance Day	24	11	20
Maxville Santa Claus Parade	54	25	38
Maxville Tree Lighting	28	14	21
Polar Bear Dip	14	6	16
Recreation Associations' Community Breakfasts	31	9	24
Summer Camp at Island Park	9	4	11
Women's Day	39	17	39
WOW (Glengarry Artists Collective	24	22	13
Youth Unlimited Summer Camp at Maxville & District Sports Complex	5	3	7
<i>Other</i>	4	1	3
TOTAL	965	467	900

Other

- Maxville Lions Club Breakfasts 2
- Scouts- Maxville 1

15. Which of the Township facilities or features do you or others in your household use at each of the following parks? (Select all that may apply)

			Responses
Apple Blossom Park (Apple Hill)			52
	• Ball Diamond	6	
	• Community Hall	14	
	• Play Structures	13	
	• Soccer Field	19	
	• Other	0	
Centennial Park (Maxville)			40
	• Green Space	33	
	• Other	7	
Clark-MacIntosh Park (Dunvegan)			36
	• Community Hall	4	
	• Play Structures	6	
	• Soccer Field	25	
	• Other	1	
Dalkeith			34
	• Community Hall	10	
	• Dalkeith Library Plus Building	3	
	• Outdoor ice rink or asphalt surface	17	
	• Play Structures	4	
Father Gauthier (Lochiel)			41
	• Soccer Field	40	
	• Other s	1	
Glengarry Sports Palace (Alexandria)			220
	• Ball Diamond	36	

	• Cement slab in the summer	13	
	• Community Hall	48	
	• Ice rink in the winter	58	
	• Soccer Field	63	
	• Other	2	
Glen Robertson			19
	• Cement slab in the summer	2	
	• Community Hall	8	
	• Outdoor ice rink in the winter	4	
	• Play structures	5	
	• Other	0	
Greenfield			20
	• Soccer Field	20	
	• Other	0	
King George Park (Maxville)			37
	• Green Space	32	
	• Other	5	
Island Park (Alexandria)			490
	• Basketball Court	19	
	• Beach	57	
	• Boat Launch	25	
	• Community Hall (Sandfield Building)	45	
	• Gazebos	37	
	• Play Structures	63	
	• Skate Park	20	
	• Soccer Field	63	
	• Splash Pad	68	
	• Tennis Court	3	

	• Volleyball Court	8	
	• Walking Paths	77	
	• Other	5	
Laggan Public School (Laggan)			37
	• Soccer Field	35	
	• Other	2	
Maxville & District Sports Complex (Maxville)			293
	• Asphalt Pad outdoors	21	
	• Ball Diamond	21	
	• Cement slab for multisport in the summer	14	
	• Community Hall	54	
	• Covered Picnic Area	28	
	• Gondola in bleachers	22	
	• Ice rink in the winter	61	
	• Soccer Field	65	
	• Other	7	
Tim Hortons Dome (Glengarry Indoor Sports Complex) (Alexandria)			125
	• Lawn Bowling Court	2	
	• Pickleball Court	17	
	• Tennis Court	8	
	• Turf	45	
	• Walking or Running Track	45	
	• Other	8	

Other

- Broadsword 1
- Fishing Alexandria Island Park 2
- Maxville Fair grounds for walking and snowshoeing 2

- Maxville Market and Tree lighting 1
- Open field time 1
- Play structures in Maxville 1
- Volleyball 1

16. Which of the following do you/others in your household use for programs/self-directed interests?

Glengarry Golf Course / Terrain de golf Glengarry	62
Alexandria Library / Bibliothèque d'Alexandria	54
Glengarry Pioneer Museum / Musée des pionniers de Glengarry	45
Maxville Library / Bibliothèque de Maxville	33
Alexandria Legion / Légion à Alexandria	27
Centre Lochiel Center	20
Carefor Health & Community Services Alexandria	18
I/we do not use any of these facilities/features / Je n'utilise/nous n'utilisons aucune de ces installations	18
La Fraternité Alexandria	16
Sacred-Heart Church / Église du Sacré-Cœur d'Alexandria	16
Le Centre Culturel Les trois p'tits points	12
Historic cemeteries / Cimetières historiques	10
Alexandria United Church / Église unie d'Alexandria	8
Kirkhill United Church / Église unie de Kirkhill	6
Kenyon Presbyterian Church / Église presbytérienne de Kenyon	5
St. Catherine of Sienna Catholic Church / Église catholique Sainte-Catherine de Sienne	5
St. Anthony Catholic Church / Église catholique Saint-Antoine	4
St. James Catholic Church / Église catholique Saint-James	3
Cedar Valley Mennonite Church of God / Église mennonite de Dieu Cedar Valley	0
St. Michael and All Angels Church / Église Saint-Michel et tous les anges	0
Other	12

374

Other

- Alexandria Lions Club 1
- Curling Club 1

- Dunvegan Recreation hall 1
- Ecole Secondaire Le Relais, GDHS 1
- Glen Robertson 1
- Glen Robertson Recreation Center + Club 50+ 1
- Golf course-social golf and tournaments 1
- Golf tournaments 1
- I dont know what is available 1
- SDG library online 1
- Social-dancing at the Legion, 1
- St Finnans Basilica 4
- St Martin de Tours church 1

17. List the recreation activities you participate in these other facilities.

Golf	5
Church worship service	4
Reading newspapers/books	4
Art shows	2
Glengarry Pioneer Museum	2
Soccer	2
Yoga	2
Canada Day festivities	1
Card games	1
Community Events	1
Concerts	1
Crossfit	1
Evening suppers	1
Festivals	1
Fund raisers, rink,	1
Hiking	1
Hockey	1
Information	1
Legion	1
Lions Club breakfasts	1

Lochiel Centre	1
Minor Hockey and Minor Baseball	1
Paint Class	1
Performing Music & Mayhem shows	1
Running	1
Sand bag	1
Senior group exercise program	1
taking out books and using activities at the library	1
Volleyball, Off Ice hockey training	1
Walking at Maxville Fairgrounds	1

18. Do you or others in your household use the Glengarry Trails in the Township of North Glengarry?

Yes	131
No	42
Uncertain	6

19. Which of these uses for the Glengarry Trails apply to you/others in your home? (Select all that apply)

Walking or Dog Walking	126
Running	12
Snowshoeing	38
Cross Country Skiing	18
Cycling - Biking	20
<i>Other</i>	5

TOTAL 219

Other

- ATVing
- Geo tagging
- snowmobile
- Swimming

20. Can you add any other facilities or programming/activities in North Glengarry that have not yet been listed?

HGMH Pool	3
-----------	---

Maxville Fair Grounds - Most beautiful grounds in Eastern Ontario ...used by many...every day!	2
Swimming / Lessons	2
Activities for youth that isn't about organized sports.	1
Athletic bar	1
Ballroom dancing, dance, art that is affordable for people 55 an over	1
Boot camp	1
Curling club	1
It would be great if the Maxville arena hall could have Early-On play dates for babies and toddlers, as they have this for several other surrounding communities.	1
Karate	1
Maxville curling club	1
Multi Sports area	1
Outdoor Walking Trail Maxville	1
Play structures in Maxville	1
Roller skating, scooter	1
Ski doo trails	1
Splash Pad Maxville	1
The glengarry air cadets wasnt identified on this list. My kids participate in that group and its wonderful!	1
Township run camps	1
Water Fountain in Maxville	1
We need to have more program's for special needs. High functional special needs.	1
Youth Basketball Net Maxville	1

NEED FOR IMPROVEMENTS TO FACILITIES, PARKS AND TRAILS

We are interested in your opinion on improvements to Township recreation facilities, trails, and parks.

21. Do you think the Township’s recreation facilities, trails and parks require improvements?

Yes	97
No	20
Uncertain	52

22. What types of improvements are needed to the Township's facilities & parks? (Select all that apply)

Washrooms / Salles de toilettes	52
More shade, seating, lighting, etc. / Plus d'ombre, de sièges, d'éclairage, etc.	47
Improved access to beach / water for swimming, kayaking, canoeing, etc. / Amélioration de l'accès à la plage/à l'eau pour la baignade, le kayak, le canoë, etc.	45
Arena repairs Maxville / Réparation à l'aréna de Maxville	44
More water play features / Ajout de jeux d'eau	42
Water fountains / Fountains d'eau potable	40
Better playing fields for soccer / De meilleurs terrains de jeu pour le soccer	38
Outdoor gym/fitness stations / Stations de gym/fitness en plein air	36
Food gardens / Jardin alimentaire	35
Increased maintenance/clean up / Entretien/nétoyage accru	31
More walking paths to within/parks / Plus de sentiers pédestres vers et à l'intérieur des parcs	30
Covered areas (gazebos) / Zones couvertes (gazebos)	27
Multi-purpose play court / Terrain de jeu polyvalent	24
Better playing fields for baseball/softball / De meilleurs terrains de jeu pour le baseball/balle-molle	20
New/improved play equipment / Équipement de jeu nouveau/amélioré	15
Arena repairs Alexandria / Réparation à l'aréna d'Alexandria	11
Better playing fields for other turf sports / De meilleurs terrains de jeu pour d'autres sports sur gazon	8
AODA accessibility improvements / Améliorations de l'accessibilité selon l'APHO	7
Concrete pads for wheel sports / Parc en béton pour sports de roues	7
<i>Other</i>	25

Other

- Swimming Pool 6
- Bike paths/lanes, safe bike areas 4
- Lights for maxville soccer feild 3
- Dog park 2
- Splash pad for Maxville!! 2

- Swimming Lessons at HGMH 2
- Indoor pool and a outdoor pool for the ones who do not enjoy refreshing in the islands water. 1
- Larger library spaces 1
- Maxville outdoor basketball court with lights 1
- More garbage cans, picnic tables, better hours at library and public washrooms 1
- More shaded seating areas in Maxville 1
- No improvements needed in Maxville. There is already too much focus on recreation and not enough on other civic matters and issues. Maxville would benefit greatly from more attention being paid to issues such as speeding on Main Street. 1
- Outdoor track. The track at Glengarry District High School is in rough shape. This is a space that is used by students as well as members of the community in the evenings, weekends, holidays, etc. 1
- Tennis court repair at the Dome 1
- Tennis courts 1
- The washrooms are not open all season near the play structures. As part of a large homeschooling community, this is not convenient. 1
- Water Fountain at Maxville Soccer Fields 1

23. Please list up to 3 facilities and parks that you think are in most need of improvements.

#	Comments
Island Park	
3	Alexandria beach upgrades
1	Alexandria water park
1	Baseball diamond Alexandria
1	Beach water should be managed and posted for safety of swimming etc.
2	Indoor pool
1	Outdoor pool
1	Park structures Alexandria

1	Swimming area at the park
1	There was a life guard on duty.
1	Washrooms, shaded areas and new play equipment
Glengarry indoor sport complex	
1	Dome court area - surface in need of repair and really bad lighting - especially the outer sides of the court
Glengarry sports palace	
2	Arena dressing rooms , especially the showers
1	Baseball diamond needs to be sand with an actual mound, and needs more shade
1	Hand rail at Glengarry Sports Palace. At least one between section 1 & 2.
1	Have one softball field and one baseball field at arena
1	Need an outdoor rink in Alexandria
Maxville & district sports complex	
3	A splashpad would be great for kids watching their sibilings play soccer games and daily use
16	Lighting to be added to large soccer fields in Maxville for late games to be played
1	Maxville Arena also needs to cater to its LOCAL users better rather than give prime ice time to associations from out of town.
1	Maxville arena parking lot
2	Maxville arena playground
1	Maxville ball diamond
1	Maxville centennial park
9	Maxville Hockey Rink requires modernization
4	Maxville multi-use hard surface/court
1	Maxville Seating Minor Soccer fields
1	Walking trail around maxville
1	Washrooms and shower areas
1	Washrooms and water (fields?)
Other	
1	Alexandria library
1	Ball diamond in Apple Hill to be re-established
1	Ball diamonds, soccer fields outside of Alexandria, Island Park
1	General cleaning
1	Glen Robertson access to outdoor washrooms
1	Glengarry trails
2	Laggan soccer/tennis

1	Lochiel soccer field
1	Mill- Square, walking path that connects to island park
1	Play structures at lochiel soccer field or community

24. Do you think the Glengarry Trails require improvements?

Yes	42
No	51
Uncertain	80

25. If yes, what types of improvements do you think are needed to the Glengarry Trails? (Select all that apply)

Amenities along trail (e.g., washrooms, benches, picnic spots) / Commodités le long du sentier (p. ex. toilettes, bancs, aires de pique- nique)	40
More/improved trail heads (e.g., parking, trail maps/details, washrooms) / Améliorer les installations au début des sentiers (p.ex. stationnement, cartes/détails des sentiers, toilettes)	25
Signage and wayfinding along trail / Signalisation et panneau d'orientation le long du sentier	22
Better trail maintenance / Meilleur entretien des sentiers	20
More patrols/monitoring / Plus de patrouilles/surveillance	11
Educational/stewardship initiatives / Initiatives d'éducation/d'intendance	7
Better AODA accessible segments / Meilleurs segments accessibles en vertu de l'APHO	3
<i>Other</i>	4
	132

Other

- Allow horseback riding
- For bike riding
- More/better mountain bike trails. More trails and grooming for cross-country skiing, including skate skiing.
- Some *areas* flood often and another small bridge would be nice

Do you have any comments you would like to share regarding the Glengarry Trails?

- An absolute gem for our community. Maybe we need more acknowledgement of the dedicated volunteers who keep the trails in order.
- Full of dog poop
- Glengarry Trails are wonderful and we're very thankful to the people that help to maintain them.
- I am new in the area and I learned a lot about facilities and events from this survey. I would like to receive news about events via email if it is possible
- I would like cross county ski trails again
- Last time I was there, walking long distances alone didn't feel safe.
- More information/maps for them and easier to find these. Its hard to know where to go if you haven't already been there
- Please add more programs for 55 plus and advertise!
- There have been some great improvements over the years! (E.g. Rail on bridge)
- They are awesome! Such a gem! So lucky to have them!
- Truly a gem in our community. Volunteers cannot do it all.
- We absolutely love the Glengarry trails in every season!
- We are so fortunate to have this gem in North Glengarry
- Well maintained. The only improvements needed is that we should get more trails! I use them with my family often.
- Wonderful asset for the People of North Glengarry and Surrounds

USE OF RECREATION SERVICES IN SURROUNDING COMMUNITIES

When responding to the questions above, you may have identified that individuals in your household participate in recreation activities in surrounding communities. We are interested in your household's use of recreation services in communities outside the Township of North Glengarry, and why you use them.

26. How often do you or others in your household participate in recreation activities in the following communities?

	Frequently (about 1/wk or more)	Occasion- ally (about 1/month)	Rarely (2-3 times per year)	Never
Township of South Glengarry	18	26	60	65
City of Cornwall	31	29	47	60
Township of Champlain	3	13	39	113
Municipality of Casselman	6	14	35	113
Town of Hawkesbury	9	6	32	121
Ottawa and surrounding areas	13	33	53	69
Montreal and surrounding areas	3	23	46	96
<i>Other</i>	0			
TOTAL	83	144	312	637

Other

- Horse riding trails, ATV trails 1
- Kingston, Ottawa 1
- Larose Forest, central Ontario,
Adirondack's 1
- North Stormont 2
- Swim at family cottage in laurentiens. 1

27. List the recreation activities accessed in these other communities.

Soccer	14
Hockey	12
Walking/hiking trails	11
Pools (swimming / lessons)	10
Baseball	7
Biking trails (1 indicated asphalt bike trail)	8
Golf	6
Park	6
Splash pad	5
Gym	4
Indoor pool	4
Skiing/snowboarding	4

Aquafit	3
Arenas	3
Beaches	2
Boat Ramp (1 indicated 115hp)	2
Broomball	2
Concerts	2
Horseback riding	2
Lacrosse	2
Skating	2
Theatres	2
Toboggan hills	2
Yoga	2
Arts	1
ball hockey	1
basketball	1
Bingo	1
Bird conservatory	1
Bowling	1
Camping	1
Canoeing	1
Church	1
Cross-country ski	1
Curling	1
Cycling	1
Dancing	1
Dining	1
Fairs	1
Fitness Training	1
Golf dome	1
Gymnastics	1
Horse riding arena	1
Horse trails	1
Kayaking	1
Markets	1
Museums	1
Music	1
NHL Hockey	1
OFATV St Lazare Warwick Larose Limerick Forests	1
Outdoor concerts	1

Outdoor hockey	1
Parades	1
Picnics	1
School activities	1
Senior group exercise program	1
Skateboard parks	1
Skidoo trails	1
Softball	1
Special events	1
Specialized gyms	1
Tennis	1
Trampoline	1
Tree top trekking	1
Volleyball	1
Zumba	1

28. Why do you use recreation services in these communities? (Select all that apply)

I/we use services that are not available in the Township of North Glengarry	70
I/we use them in conjunction with trips to shops, etc.	49
Facilities/programs are better	31
Leagues are based outside of North Glengarry	31
Family members can participate at the same time	27
Activities are more affordable	17
I/we don't know what's available in North Glengarry	15
I/we use private/commercial facilities	14
Hours are more convenient	14
Activities are closer to home	12
Services are AODA accessible	0
<i>Other</i>	21
	301

Other

- GSL uses South Glen facilities / Fields used in conjunction with gsl 2
- Not available in North Glengarry 2
- Access different golf courses 1
- Biking trails 1

- Competitive sports 1
- For variety 1
- Friends and family reside in quebec 1
- In university 1
- Kids attend school in Casselman, parents work in Ottawa. Casselman is not out of our way. 1
- Larger and better equipped gym 1
- Live in these communities part time 1
- Public pool not available in ng other than the therapy pool which is not conducive to swimming 1
- Skateboard parks are visited for variety 1
- Soccer games schedules in different towns 1
- Soccer levels are actually for children that age. Not combined years of up to five years older like GSL and better pricing. 1
- Variation 1
- When participating in activities in North Glengarry I have witnessed bias activities from leagues and coaches. This is one of the main reason why it is not enjoyable for children to participate in local activities. 1
- Work in Hawkesbury 1

RECREATION PROGRAM/ACTIVITY, FACILITY AND PARKS NEEDS

The next few questions ask about your interests in having additional recreation services made available in the Township of North Glengarry that the different age groups in your household would use.

29. Are you and members of your household able to participate in recreation activities as often as you would like (e.g., Sports, Fitness, Outdoor play, etc.)?

Yes	83
No	44
Uncertain	30

If you answered No, please indicate why you or a member of your household was unable to participate.

Not enough available / available hours <ul style="list-style-type: none"> • Activité pour les 55 ans + • Adult Social activities Maxville area • Desired activity not available or better quality elsewhere • I would participate in more activities if they were closer to home and affordable. Cornwall has more options but Alexandria would be a primary choice of location for yoga, dance, sports, swimming. • Many activities occur at the same time, not a lot of options for different times/locations • Not available not enough time and not all activities are offered in our community • Not knowing what is available • not much of interest is offered here. • The available hours don't always work with my work schedule • There is no Community Swimming Pool • There isn't a lot around • There isn't a lot offered in Maxville for the over 55 category • Used to attend outdoor boot camp in Maxville but no longer available • We often need to go out to Cornwall or other township to participate in the activities • yoga is not offered through the summer months 	16
Scheduling conflicts (work, school)	6
Cost	5
Lack of time / Time constraints / Timing of activities	4
mobility but working on it	2
No pool available / No pool for aquafit	2
Conflicting priorities	1
Driving Distance to Travel to Soccer requires Field with Lights form Maxville	1
GSL is always combined for indoor and outdoor with too much of an age gap so we go outside the area for that and other areas have better pricing	1
Ice time availability	1
lack of available resources	1
Parents too busy with kids to participate	1
Sidewalks and paths poorly plowed if even plowed	1

30. Are there additional recreational programs and activities that you would like to see provided at parks or recreation facilities in the Township of North Glengarry and that you or others in your household would use?

Yes	83
No	23
Uncertain	51

31. What types of new/expanded active sport/fitness programming or opportunities would members of your household used if provided in the Township of North Glengarry? (Select all that apply)

Water-Based Activities (e.g., Canoe, Kayak, Swimming, etc.)	61
Group Fitness Classes (e.g., Aerobics, Zumba, Yoga, etc.)	45
Court Sports (e.g., Tennis, Pickleball, Badminton, etc.)	37
Arena Ice Activities (e.g., Hockey, Figure Skating, Broomball, etc.)	30
Field Sports (e.g., Soccer, Lacrosse, Ultimate Frisbee, etc.)	27
Arena Non-ice Activities (e.g., Floor Hockey, Box Lacrosse, Roller Derby, etc.)	26
Martial Arts (e.g., Karate, Tae Kwon Do, Jiu Jitsu, MMA, etc.)	20
Gymnasium sports (e.g., Basketball, Volleyball, etc.)	19
Outdoor Ice Activities (e.g., Learn to Skate, Shinny, etc.)	19
Wheel Sports (e.g., BMX, Fat biking, Skateboarding, etc.)	15
None of the above	9
<i>Other</i>	18
	326

Other

- Dance 3
- Gymnastics 3
- Swimming pool 3
- Mountain biking 2
- Outdoor pickleball 2
- Swimming Lessons (1 indicated at Island Park) 2
- Arts 1
- Baseball 1
- Canoe activities 1

- Choirs 1
- Cross-country ski 1
- Horse trails 1
- Learn to skate type camp prior to hockey season starting in September. Currently have to travel to Ottawa for anything like this. 1
- Music 1
- Outdoor fitness groups 1
- Outdoor track and bike path 1
- Senior biking 1
- Splash pad 1
- Squash 1
- Swimming for adults 1
- Tobogganing hill like the one in Saint-Constant (QC) for example. 1

32. What types of new/expanded non-sport programming or recreation opportunities would members of your household use if provided in the Township of North Glengarry? (Select all that apply)

Wellness programs (e.g., Tai Chi, Mental Health, etc.)	47
Artisanal (e.g., Quilting, Handmade food, Sculpting, etc.)	41
Visual Arts (e.g., Painting, Photography, Digital Media, etc.)	38
Learning/Self-improvement (e.g., Local heritage, Nutrition, Computer, etc.)	34
Social/Club Activities (e.g., Youth Drop-ins, Seniors, New Parents, etc.)	33
Environmental (e.g., Pollinator Gardens, xeriscape gardening, etc.)	26
Performing Arts (e.g., Drama, Choral, etc.)	26
Seniors' Programs	23
Camps (e.g., Day, Summer Break, Winter Break, etc.)	21
None of the above	17
Before and after school programs	14
Play programs for preschooler	13
<i>Other</i>	2
	335

Other

- Activité d'intégration pour nouveau immigrants dans la région. Nous en avons beaucoup. 1
- Fitness Training Outdoor 1
- Swimming Pool 1

33. What is your level of satisfaction with parks and recreation opportunities in the Township of North Glengarry for the following age groups that reside in your home?

	Not satisfie	Not satisfie	Neither satisfie	Satisfie	Very satisfie	Don't know /
Preschoolers 0 - 4 years	3	11	7	14	4	5
Elementary School age 5 - 12 years	2	7	17	22	10	4
High School age 13 - 19 years	5	9	16	22	4	5
Young Adults 20 - 34 years	3	4	13	15	4	4
Adults 35 - 54 years	4	9	22	39	10	4
Older Adults 55 - 64 years	3	8	11	19	6	6
Seniors 65 - 74 years	3	4	8	16	5	2
Seniors 75 years and older	3	2	6	5	1	5
TOTAL	26	54	100	152	44	35

34. Please indicate your level of agreement with the following statements regarding the Township's facilities and programming only:

	Strongly Disagree	Disagree	Neither Agree or Disagree	Agree	Strongly Agree	Don't know / Don't use
My household is satisfied with the location of parks and recreation facilities in the Township	1	12	31	84	24	5
The Township's parks and recreation facilities are well maintained	3	15	29	82	22	6
The Township's recreation programs are affordable	5	15	34	73	14	16
My household feels well informed about local parks, recreation events and activities	10	35	38	63	7	4
Parks and recreation services should be a high priority for Township Council	4	3	16	66	66	2
TOTAL	23	80	148	368	133	33

35. Would you or others in your household attend one-day or weekend community-wide events if they were offered in the Township?

Yes	83
No	44
Uncertain	30

36. If yes, what types of events would you be interested in attending?

Festivals and shows: <ul style="list-style-type: none"> • Music events / festival • New events • Themed events • Street festival! With live music vendors and food • VKH recently held a May Main Street event. So many people! • Small halls music • Dances 	14
Sports: <ul style="list-style-type: none"> • Fitness training • Bike days • Karate • Kayak meet ups • Soccer training clinics • Sports fundraiser or tournament (hockey curling baseball hockey volleyball) • Swimming pool 	8
Fairs: <ul style="list-style-type: none"> • Community fair we don't have one • Fairs like Williamstown • Family oriented activities for younger children or outdoor fairs 	4
Senior activities: <ul style="list-style-type: none"> • Outdoor activities • Senior hockey • Senior trips 	4
Family friendly activities: <ul style="list-style-type: none"> • Anything a whole family can enjoy together for a day rain or shine • Kids activities • Family gatherings • Family fun days • BBQ 	3

<ul style="list-style-type: none"> • STEM activities etc 	
Arts and crafts <ul style="list-style-type: none"> • Arts workshops • Quilting • Painting 	3
Museums activities: <ul style="list-style-type: none"> • Museums • Art exhibition 	2
Wellness Workshops: <ul style="list-style-type: none"> • Meditation • Yoga 	3
Other: <ul style="list-style-type: none"> • Atv • Gardening • Group outdoor activities - like the cornwall outdoor club we used to belong to • Hobby farm • Horse trails • Local show case • Newcomer activities / outreach • Races 	8

37. Please indicate if your household would contribute to the development of recreation facilities, parks and trails through each of the following methods. (Select all that apply)

Volunteering to help run programs/activities	56
Joining a volunteer stewardship group	44
Organizing/assisting with local fundraising events	40
Paying more fees to use services	37
Donating an amenity for a park (e.g., bench, tree, picnic table, etc.)	35
Donating money to a capital campaign	34
Accepting an increase in property taxes	32
<i>Other</i>	4
	282

Other

- Help out at events

-
- It depends what for - if we could get an indoor pool, it would help in any way possible!!!
 - No taxes are high enough
 - Too old to consider more expenses

38. If there are any additional comments you would like to make for consideration in the Parks and Recreation Plan, please provide them below.

- A community swimming pool would be great, because the gmh no longer offer that service. There are no more swimming lessons for kids and no aqua-fitness for 55+ in age. That's why we go to Cornwall
- A dog park would be an asset in our community!
- AC for the Tim H Dome
- Finding out more information on where to be able to use amenities, such as swimming pools. We live in South Glengarry currently, work in Alexandria and will be moving family to Alexandria
- Fix the GSL a problem before the league folds here in Glengarry. Huge amounts of North Glengarry residents playing elsewhere
- Having kind of info for back to basics daily life with using low expensive supplies, creating daily life healthy way of living. Young generations could benefit and older generation could bring info. All could benefit from learning to survive in a more natural way.
- Hire a more competent head of recreation
- I would love to see a multi sport complex with a gym, pool, multipurpose room - like a YMCA with child care while I can workout. The Dome needs to be bigger. We need a pool - both indoor and outdoor that is open to the public for free swimming.
- It would be nice to see a bowling alley return or drive in
- It's impossible to find an adult volleyball league in the region
- Lights at the Maxville soccer field.
- Lights for the Maxville soccer fields
- Maxville needs to be focused on as a young and growing village.
- Need to focus on the smaller towns, not everything about Alexandria
- Off road ATV trails (not roads), horse riding trails, kayak

-
- Please consider funding for installing lights at the Maxville Soccer Field. It is a vital improvement to the town in order to keep a thriving soccer community for U17 and above.
 - Please fix the weed problem at Loch Garry. The water consumption has drained the lake and the weeds are overtaking it. Local residents can't enjoy the lake because it is now prioritized for drinking rather than wellness.
 - Smaller areas in NG are ignored! We pay just as much in taxes and receive way less services.
 - Swimming lessons for children
 - The Christmas tree that was erected in Maxville was beautiful. The lights w
 - This region is expanding. Lets be pro-active and set up the infrastructure now, so the families who live here now can benefit from a sense of ownership and pride because theyre building a string community.
 - To maintain facilities we have - especially ones outside of Alexandria. We have heard of hockey teams being told there is no availability in Maxville even though many Saturdays in the winter we could see the parking lot empty. There are teams all over that would pay to use this ice time!!
 - Transportation like a weekly bus for Alexandria and to Cornwall
 - We would definitely not support a property tax increase to contribute to the development of recreation facilities, parks and trails as we do not use any of these. These would be supported better through users paying more fees to use services. Those who use them should shoulder the burden of improvements and costs, not those citizens who never use these services.



**STAFF REPORT TO THE
COMMITTEE OF THE WHOLE**

Report No: CS-2024-09

February 27, 2024

From: Anne Leduc – Director of Community Services

RE: Ice Resurfacer for Maxville

Recommended Motion:

THAT the Committee of the Whole receives Staff Report CS-2024-09 for information purposes.

Background / Analysis:

As part of the annual budget cycle staff prepares a 10-year Capital Budget Plan which contains placeholders for the funding of various capital projects. The 10-year Capital Budget for 2025 includes \$175,000 towards the replacement of the ice resurfacer for the Maxville & District Sports Complex.

The Olympia Ice Resurfacer for the Maxville & District Sports Complex was purchased in 2004 and is at the end of its lifecycle (see pictures attached).

Presently, staff is having issues with the unit and the parent company that services the unit has quoted \$2643.50 plus HST to perform a diagnostic emissions test. There would be extra charges for any additional testing that goes beyond the emissions test as well as charges for the repair itself. Based on experience, repairs of this nature can run well over \$6,000. Staff has reached out to operators and mechanics that deal with propane motors to see if this work could be done locally. Unfortunately, due to the specialized nature of this piece of equipment, we were unable to contract locally for the testing or repairs.

Staff has contacted the regional distributors for ice resurfacers to obtain information on availability and timeline on order deliveries. At the time that this report is being submitted, the timeline to order a new ice resurfacer can vary from 8 to 12 months. Staff proposes to bring a report to Council at the March 25, 2024, meeting to issue a Request for Proposal for the supply

and delivery of an ice resurfacer for the Maxville & District Sports Complex. A report would be brought back to Council to award the contract to the successful proponent. Staff expects that the costs for the ice resurfacer would be disbursed in the 2025 Capital Budget cycle.

In its Corporate Strategy, Council directed staff to promote and encourage environmental stewardship in the Township. As well, as part of its reporting obligations to the Province of Ontario, under the Ontario Regulation 507/18: Broader Public Sector: Energy Reporting and Conservation and Demand Management Plans, the Township of North Glengarry is required to report on the steps it takes to increase energy efficiency and reduce energy costs and greenhouse emissions. As part of the Request for Proposal, staff would include specifications for an electric ice resurfacer which aligns with the Council and Province's mandates.

Alternatives:

Production time for ice resurfacers can vary between 8 to 12 months. Staff suggests that a report be presented to Council to issue a Request for Proposal for a new ice resurfacer.

Financial Implications:

There may be a small deposit required in 2024 to secure the unit into production but the majority of the costs would be disbursed in the 2025 Capital Budget cycle.

Delaying the purchase increased the repair costs on a unit that has for all intents and purposes outlived its lifecycle.

Units are available as emergency rentals but can easily reach a quarter of the cost of a new ice resurfacer if it was rented for a full ice season (basically the equivalent of the production period for a new ice resurfacer). As an effort to prevent unnecessary spending, staff privileges a preparedness approach to the replacement of this important piece of equipment.

Attachments & Relevant Legislation:

Attached - Pictures of the Olympia

Others Consulted:

Zoe Bougie – Director of Finance
Jerome Andre – Facility Equipment Operator

Reviewed and Approved by:
Sarah Huskinson, CAO/Clerk

Pictures of the Olympia









STAFF REPORT TO THE COMMITTEE OF THE WHOLE

Report No: TR-2024-08

March 20, 2024

From: Zoe Bougie – Director of Finance/Treasurer

RE: 2023 Reserve Update

Recommended Motion:

THAT the Committee of the Whole receives Staff Report No. TR-2024-08 2023 Reserve Update;

AND THAT the Committee of the Whole recommends to the Council of the Township of North Glengarry to approve the transfers to and from reserves as outlined in Schedule A.

Background / Analysis:

As required by legislation, Council must approve transfers to and from reserves. This report summarizes the request to confirm transfers done in 2023. This report also summarizes the carry forward amounts for projects that were approved in 2023 but were unable to be completed. These transfers will ensure that the balance in each reserve account reflects the actuals.

North Glengarry Working Reserve

Council approved \$20,000.00 towards the replacement of computers and software upgrades. Only \$8,000 was spent with the remaining \$12,000.00 being carried forward to be used in 2024.

R.A.R.E. Reserve

Council approved \$30,000.00 to replace the HVAC system in the sorting room at R.A.R.E. Staff were able repair the HVAC instead of replacing the system at a cost of \$13,080.50.

Elections Reserve

\$7,500.00 was approved as a transfer to reserves as part of the 2023 operating budget. Funds were transferred out of the reserve to cover the \$2,584.00 of expenditures which were accumulated throughout the year.

Planning Reserve

\$5,000.00 was approved as a transfer to reserves as part of the 2023 operating budget.

Recreation Working Fund

In 2023, Council approved \$35,000.00 for upgrades to the Dalkeith outdoor rink as well as building upgrades. This work was unable to be completed and the funds will be carried forward to 2024.

Modernize and Efficient Reserve

\$100,000.00 was approved for the purchase of a records management software and \$70,000.00 for fire training props, both funded through the Modernize and Efficient Reserve. The final expenses were \$39,686.42 and \$69,359.66 respectively.

Facilities Reserve

Due to the sale of buildings, \$306,972.00 was transferred into the Facilities Reserve.

Fleet Reserve

Staff purchased a new SUV for the Public Works department, a slip in water tank for the Roads department and a pickup truck for the Fire Department for a total of \$124,905.94 funded from the Fleet Reserve. Surplus vehicles were also disposed of and \$21,234.72 was transferred into the Fleet Reserve as a result from the sale of the vehicles.

Canada Community Building Fund Reserve (formerly Federal Gas Tax)

\$330,569.94 was used towards the paving that was completed in Glen Robertson. The remaining amount of \$156,242.36 will be carried over to 2024 to fund new road projects.

Fire Reserve

\$30,000.00 of funds will be carried forward to 2024 to fund renovations for three fire stations.

Infrastructure Reserve

\$618,757.64 was not spent in 2023 and will be carried forward to 2024.

Waste Disposal Site Reserve

\$50,000.00 was approved as a transfer to reserves as part of the 2023 operating budget.

Cash in Lieu of Parkland Reserve

Throughout 2023, \$14,000 of revenue was earned. At year end, this amount is transferred into the reserve.

Maxville Soccer Lights Reserve

Council approved funds allocated for the Maxville Soccer Lights to be redistributed to the asphalt pad in Maxville at a cost of \$ 20,070.35.

North Glengarry Sewer Reserve

\$140,000.00 was approved for Phase 3 of the Alexandria Sludge Removal. Of this only \$22,358.72 was spent, with the remaining \$117,641.28 being carried forward to 2024.

Schedule A shows the transfers to and from reserves as well as the amounts carried forward for 2024. Schedule A also shows the beginning and ending balance for each reserve.

Alternatives:

1. Council approve the transfers to and from reserves (recommended)
2. Council does not approve transfers to and from reserves

Financial Implications:

The approved 2023 budget included \$499,800.00 to be transferred from reserves and \$62,500.00 to be transferred to reserves for a net decrease to reserves of \$437,300.00.

Due to additional transfers in to reserves as well as work that was not completed, there will instead be a net increase to reserves of \$795,091.49.

2022 Ending Balance	2023 Transfers In	2023 Transfers Out	2023 Carry Forward	2023 Consolidated Totals In/Out	2023 Ending Balance
-	-	\$600,256.51	-	-\$795,091.49	-\$9,180,313.58
\$8,385,222.09	\$425,706.72		\$969,641.28		

Attachments & Relevant Legislation:

Schedule A – Reserve Transfers

Others Consulted:

Sarah Huskinson, CAO

Reviewed and Approved by:
Sarah Huskinson, CAO/Clerk

Schedule A - Reserve Transfers

Reserve Name	Account	2022 Ending Balance	2023 Transfers In	2023 Transfers Out	2023 Carry Forward	2023 Consolidated Totals In/Out	2023 Ending Balance
Working Funds							
CEMC Contingency Fund	1-2-2000-8126	(43,653.00)	-	-	-	-	(43,653.00)
North Glengarry General Fund	1-2-2000-8125	(1,203,850.76)	-	-	(12,000.00)	(12,000.00)	(1,215,850.76)
RARE	1-2-2000-8403	(376,852.34)	-	13,080.50	-	13,080.50	(363,771.84)
WSIB Insurance	1-2-2000-8452	(54,634.06)	-	-	-	-	(54,634.06)
Elections Reserve	1-2-2000-9436	(30,105.52)	(7,500.00)	2,584.00	-	(4,916.00)	(35,021.52)
Planning Reserve (OP)	1-2-2000-8303	(60,211.04)	(5,000.00)	-	-	(5,000.00)	(65,211.04)
Recreation Working Fund	1-2-2000-8123	(77,934.16)	-	-	(35,000.00)	(35,000.00)	(112,934.16)
Modernize and Efficiency	1-2-2000-8121	(385,230.96)	-	109,046.08	-	109,046.08	(276,184.88)
Total Working Funds		(2,232,471.84)	(12,500.00)	124,710.58	(47,000.00)	65,210.58	(2,167,261.26)
Capital Funds							
Dalkeith Library	1-2-2000-8301	(5,652.81)	-	-	-	-	(5,652.81)
Facilities Reserve	1-2-2000-8720	(164,427.53)	(306,972.00)	-	-	(306,972.00)	(471,399.53)
Fleet	1-2-2000-8120	(160,562.77)	(21,234.72)	124,905.94	-	103,671.22	(56,891.55)
Economic Development	1-2-2000-9203	(18,063.31)	-	-	-	-	(18,063.31)
Canada Community Building Fund Reserve (formerly Federal Gas Tax)	1-2-2000-9201	(341,013.33)	-	330,569.64	(156,242.36)	174,327.28	(166,686.05)
Fire Department	1-2-2000-8122	(39,699.62)	-	-	(30,000.00)	(30,000.00)	(69,699.62)
Major Capital - NEW	1-2-2000-9721	(1,003,517.33)	(21,000.00)	-	-	(21,000.00)	(1,024,517.33)
General Capital	1-2-2000-9121	(103,679.73)	-	-	-	-	(103,679.73)
Maxville Sports Complex	1-2-2000-8451	(55,143.28)	-	-	-	-	(55,143.28)
North Glengarry General Fund	1-2-2000-9121	-	-	-	-	-	-
Infrastructure Reserve	1-2-2000-8300	(357,262.47)	-	-	(618,757.64)	(618,757.64)	(976,020.11)
Soccer Dome	1-2-2000-8127	(5,363.80)	-	-	-	-	(5,363.80)
Waste disposal site	1-2-2000-8402	(1,060,109.84)	(50,000.00)	-	-	(50,000.00)	(1,110,109.84)
Total Capital Funds		(3,314,495.82)	(399,206.72)	455,475.58	(805,000.00)	(748,731.14)	(4,063,226.96)
Specific Purpose							
GSP Slab Reserve	1-2-2000-8404	-	-	-	-	-	-
Reserve - Cash in Lieu of Parkland	1-2-2000-9439	(75,082.20)	(14,000.00)	-	-	(14,000.00)	(89,082.20)
Reserve Fund Water Meters	1-2-2000-9432	(44,516.04)	-	-	-	-	(44,516.04)
North Glengarry Water	1-2-2000-9437	(945,108.53)	-	-	-	-	(945,108.53)
North Glengarry Sewer	1-2-2000-9438	(1,728,389.37)	-	-	(117,641.28)	(117,641.28)	(1,846,030.65)
Maxville Soccer Lights Reserves	1-2-2000-8302	(20,070.35)	-	20,070.35	-	20,070.35	-
Social Services Relief Fund	1-2-2000-8129	-	-	-	-	-	-
Safe Restart Reserve	1-2-2000-8128	-	-	-	-	-	-
Skateboard Park	12-2000-9435	(25,087.94)	-	-	-	-	(25,087.94)
Total Specific Purpose		(2,838,254.43)	(14,000.00)	20,070.35	(117,641.28)	(111,570.93)	(2,949,825.36)
Total Reserve and Reserve Funds		(8,385,222.09)	(425,706.72)	600,256.51	(969,641.28)	(795,091.49)	(9,180,313.58)



STAFF REPORT TO THE COMMITTEE OF THE WHOLE

Report No: PW-2024 10

March 20, 2024

From: Timothy Wright, Director of Public Works

RE: Public Works Work Plan

Recommended Motion:

THAT the Committee of the Whole accepts report PW-2024 10 Public Works Work Plan for information purposes only.

Background / Analysis:

Development Review

The focus of Public Works currently involves collaborating with developers to ensure that delegated infrastructure construction adheres to standards and necessary environmental approvals, aiming to support developers in meeting their project timelines effectively. EVB Engineering has successfully concluded the Alexandria Hydraulic Model section of the North Glengarry Sewer Master Plan and has provided a preliminary report. The capital aspect of this plan is forthcoming, but the preliminaries were drafted into this year's budget. Utilizing the Hydraulic model, staff can provide developers with precise insights into our system, facilitating their planning processes. EVB's upcoming tasks include finalizing the Maxville hydraulic model for sewer systems and updating the water supply model, equipping the Township with similar capabilities and aiding in capital forecasting efforts.

Landfill

Public Works continues to work on the monitoring of the closed landfills in Apple Hill, Alexandria and Dunvegan as well as running the landfill in Glen Robertson. Staff are intending to simplify the ECA for the leachate ditch at the Alexandria WDS and recently provided a workplan to the Ministry on final cover for the landfill. The final cover is a big budget item, so Public Works is reaching out to those with excavation projects in the next two years who need to find a place to put clean fill.

Roads

The Roads Department has been hard at work during the busy winter season, keeping our roads to the provincially mandated minimum maintenance standards. County Road 30 has caused some issues with attempting to maintain county standards while only having Lower tier manpower. Using additional salt has somewhat alleviated this issue but it is something staff are looking into further.

North Glengarry has experienced lower than usual amounts of snow and winter weather this season which is expected to reflect well in the next variance report. Administratively, Public Works is working very hard to have all the tenders, and requests for proposals finalized before the start of the summer season. This includes sidewalk repairs and trip hazard mitigation, engineering services for bridges, bridge replacement detailed design, hard top road brushing and trimming rental, stormwater management plan required through the Ministry of Environment consolidated linear infrastructure regulations, culvert lining, weed spraying, spring gravel resurfacing, various equipment, signage inspections, bridge inspections, and minor shop H&S conformance requirements. Operational plan updates are also currently underway taking the lessons learned from last year to reorganise the roads team into work teams based on activity, one of those being the special projects group that will respond exclusively to community concerns.

The equipment for the road crossings at GDH and Industrial boulevard has arrived, and staff are working on the application with the County currently.

The roads foundations program this year is highly anticipated and promises to be a big change for the townships system as we repave Skye Road, Concession 8, Dornie, Marcoux and a portion of McCormick where staff are undertaking some road base work in house.

Staff received three SUVs for the Public Works Department. Two for the managers to reduce fuel and one for Roads staff intended to be used for quality assurance/quality control (QAQC). This has had a significant impact on our fuel consumption. Staff have also received this years ½ ton pick ups: one for Waterworks and two for Roads. Which allowed three fuel efficient trucks that were in desperate need of repairs to be retired. These trucks are currently for sale through public tender on the Township's website.

Waterworks

Waterworks has been concentrating on training new staff members who are performing well. The annual reports for 2023 were presented in a separate report and summarize the condition of the systems. The water fill station is out to tender along with the preliminary design work for Dominion St watermain reconstruction. Staff need to do some work on Bishop St station electrical work and so are working on an RFP for this as well. Valve replacements will be integrated into the work and the VFD replacement has been awarded. Staff are working on the expansion of the Glen Robertson treatment building, the pontoon motor and the Chlorine Switchover unit.

Staff continue to work on the Alexandria Lagoon detailed design and meet bi-weekly with the consultant for project updates.

R.A.R.E.

R.A.R.E. continues to trade recycled commodities for the best possible prices. Public Works is participating in the regional waste management group and have found the collaboration to be very beneficial. The group is currently working on a regional contract with GFL for waste disposal. A large

portion of the R.A.R.E. plant was freed up over the winter for storage of equipment and materials that were formally stored at the Lochiel St facility. Temporary storage solutions for this winter were found that allowed staff to get through this season for free. These solutions won't be able to be replicated and will start costing the Township money if other solutions such as utilising the space at R.A.R.E can't be found. Staff are also looking at opening the R.A.R.E. plant as a hazardous waste depot instead of doing a hazardous waste day, this will mean residents can take their materials to the R.A.R.E. plant anytime that it is open Monday to Friday 7:00am till 3:30pm.

Alternatives:

N/A

Financial Implications:

N/A

Attachments and other relevant legislation:

N/A

Others Consulted:

Public Works Department Staff and Consultants

Reviewed and approved by:
Sarah Huskinson, CAO/Clerk



STAFF REPORT TO THE COMMITTEE OF THE WHOLE

Report No: FD 2024-01

March 20, 2024

From: Matthew Roy – Fire Chief

RE: 2023 Fire Department Annual Report

Recommended Motion:

THAT the Committee of the Whole receive the 2023 Fire Department Annual Report for information purposes only.

Background / Analysis:

Council approved the enactment of a by-law to establish and regulate a Fire Department on December 13, 2021. Sections 14.17 of the North Glengarry Fire Department Establishing By-law (No. 54-2021) require the preparation of an annual report. This report fulfills the legislative requirements, as outlined in the Fire Services Establishing By-law.

North Glengarry Fire Department protects the lives, property, and environment for the residents and visitors to the Township of North Glengarry. North Glengarry Fire Department provides service from 3 stations located across the Township. The North Glengarry Fire Department team is comprised of a full-time fire chief, volunteer firefighters, and administrative, fire inspection, and education personnel.

North Glengarry Fire Department takes a proactive approach to protect our community and recognizes the importance of implementing the three lines of defense and optimizes this philosophy in all its programs. In accordance with the Fire Protection and Prevention Act, 1997, the three lines of defense are:

- Line 1: Public Fire Safety Education
- Line 2: Fire Safety Standards and Enforcement
- Line 3: Emergency Response

To meet these objectives, North Glengarry Fire Department implements the three lines of defense through programs that support the following priorities:

- Public Education
- Fire Prevention
- Fire Safety Standards and Enforcement
- Emergency Response

In 2023, North Glengarry Fire Department continued to protect the residents of North Glengarry with dedication and pride. North Glengarry Fire Department continued to focus on fire prevention, code enforcement and education outreach to reduce the number of fires and ensure residents and property owners are implementing the proper measures to stay safe. Continued investments in our equipment and training, including the NFPA certification of our members also while ensuring mental wellness will ensure that North Glengarry Fire Department personnel are provided with the necessary skills and tools to be successful. Overall, North Glengarry Fire Department is well-positioned to continue to provide effective, efficient emergency services to the residents of North Glengarry, while focusing on continued improvement.

Alternatives:

Financial Implications:

Attachments & Relevant Legislation:

Others Consulted:

Reviewed and Approved by:
Sarah Huskinson, CAO/Clerk



2023 Annual Report

North Glengarry Fire Department



NORTH GLENGARRY FIRE DEPARTMENT

MISSION

North Glengarry Fire Department's mission is to protect people and property. We work and train in a collaborative manner, while promoting fire safety initiatives.



VISION

A modern fire department, responsive to community needs, delivered by well-trained personnel with broad roles and skills.

TABLE OF CONTENTS

Message from the Fire Chief	4
Fire Department Organizational Structure	5
Administration Division	6
Fire Prevention / Public Education Division	7
Training Division	10
Suppression Division	11
Communication Division	14
Communication Division	15

MESSAGE FROM THE FIRE CHIEF



The members of the North Glengarry Fire Department are pleased to present the 2023 Community Annual Report. As an essential emergency service, we strive to achieve excellence in all service, activities, projects, and programs that we provide.

It is with pride that I look back on our achievements in the past year. With the continued support of the Mayor, Council, and Chief Administrative Office, this Department remains an exemplary organization committed to training it's firefighters to meet the emergency needs of the community and assist our citizens in building resiliency to a wide range of community risks.

Our members work and train hard to provide superior emergency response in firefighting, medical aid, and rescue services to our community. Our firefighters responded to over 260 calls for service in 2023. NGFD is committed to providing the highest level of service to our community through a comprehensive delivery of services using three lines of defence: fire safety education, fire code enforcement, and efficient emergency response.

Our first line of defence "fire safety education" continues to improve through ongoing and new local and provincial initiatives. Our local smoke alarm campaigns, along with provincial efforts, will continue to help increase fire safety within our community.

Our second line of defence "fire code enforcement" continues to focus on more of comprehensive risk management and alignment of resources to enhance code enforcement efforts. Our fire prevention division conducts mandatory inspections along with proactive initiatives in high-risk sectors.

Our third line of defence "efficient emergency response" was further developed in 2023 through enhanced training including firefighter certification of NFPA 1001 Firefighter I & II certification. Our members have remained focused in their dedication to achieving certification since the implementation of provincial regulations in 2022.

Through a consolidated effort, the three lines of defence improve fire safety, helps to reduce loss of property, injuries, or deaths, and ensure firefighter health and safety.

I would like to thank the exceptional men and women of the North Glengarry Fire Department who are dedicated and proud to serve the community's citizens and guests.

A handwritten signature in black ink, appearing to read 'Matthew Roy'.

Matthew Roy, Fire Chief

FIRE DEPARTMENT ORGANIZATIONAL STRUCTURE

North Glengarry Fire Department is organized into 5 divisions:

- Administration Division
- Fire Prevention/Public Education
- Training Division
- Communication Division
- Suppression Division

The following is the North Glengarry Fire Department Organizational Chart:

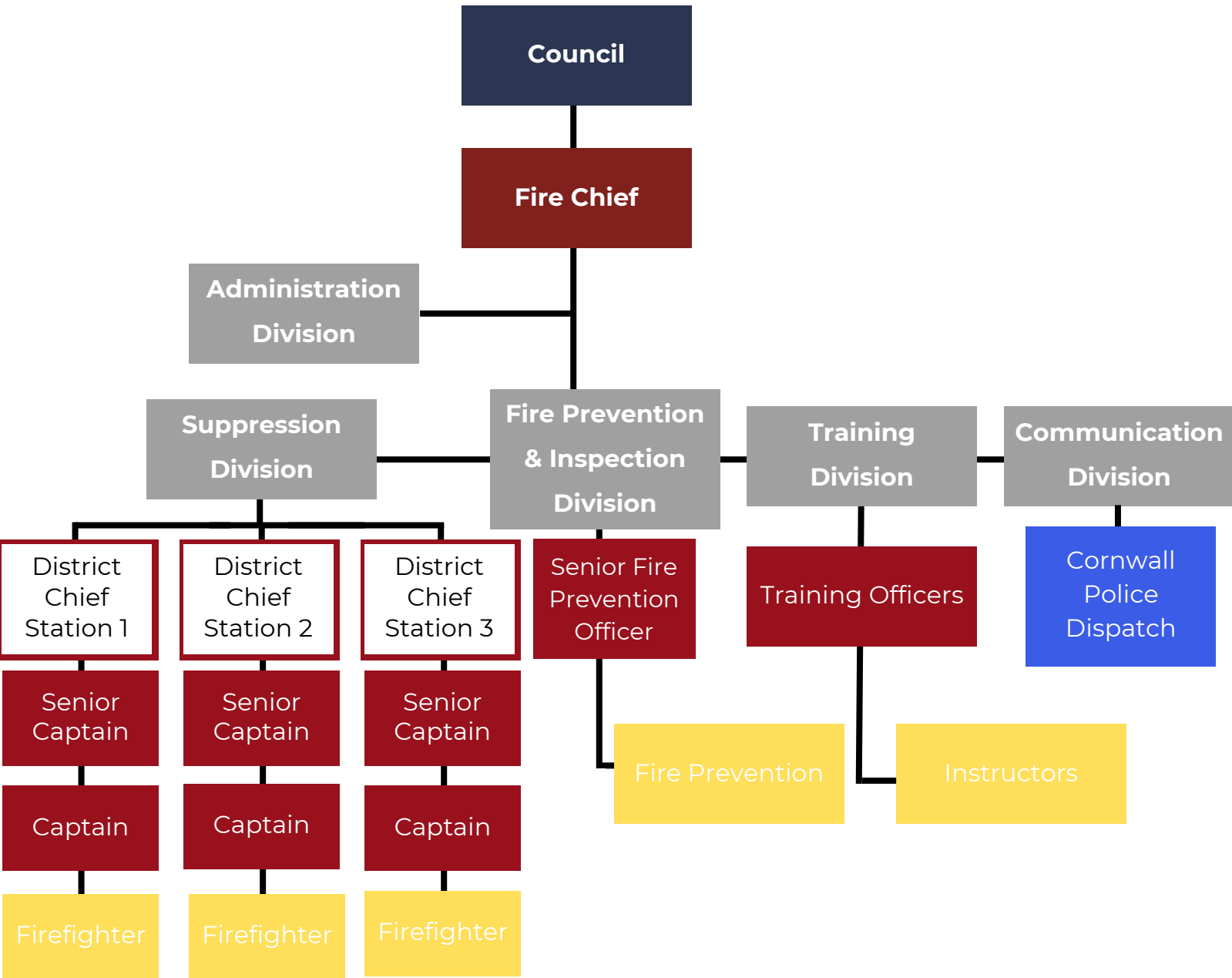

ADMINISTRATION DIVISION

The Administration Division of the North Glengarry Fire Department is comprised of the Administrative Assistant to the Fire Chief, and the Fire Chief. Administration is part of the Township of North Glengarry leadership, and is responsible for ensuring a systems approach, oversight, and transparency for all fire protection services by:

- Supporting the provision of fire protection services
- Providing training courses and schedules
- Administering the training facility
- Managing the capital and operating budgets
- Coordinating the Mutual Aid Plan and Automatic Aid agreements
- Recruiting members and celebrating retirements
- Maintaining the Township of North Glengarry Emergency Operations Centre in a constant state of readiness.

The Fire Chief sets out strategies to manage growth and sustain efficient, effective operations that enhance citizen safety and well-being.

Modernization and collaboration remain an overarching theme for the North Glengarry Fire Department. The Fire Chief develops and implements new programs and initiatives in alignment with the Township Strategic Plan to ensure a modern and efficient fire department.



FIRE PREVENTION / PUBLIC EDUCATION DIVISION

The Fire Protection and Prevention Act, 1997 (FPPA) was proclaimed into law on October 29, 1997 and introduced a new framework for the provision of fire protection in Ontario. NGFD continues to implement customer-focused changes to enhance this mandate.

NGFD is committed to reducing the loss of life and property and the protection of the environment. This is achieved through the three lines of defence. The first line is through public fire and life safety education. We continue to provide core educational, fire, and life safety messages to numerous groups and organizations. The following information highlights some of the initiatives conducted throughout 2023.

Fire Prevention Week October 8th-14th, 2023

During Fire Prevention Week, communities across Canada come together to raise awareness about fire safety and burn prevention. The theme for 2023 was “Cooking Safety Starts with YOU!”. It emphasizes simple, yet crucial, actions that individuals can take to prevent fire and protect themselves and others while cooking.

NGFD provided numerous activities and educational events to enforce the fire prevention week theme including a “TOUCH-A-TRUCK” that was a tremendous success. We were able to reach out and educate over 500 people at the event. In partnership with all the local schools, evacuation drills were conducted. These drills highlighted the importance of escape planning and early warning by having working.

Community Events

In addition to fire prevention week, NGFD participated in numerous provincial-wide safety campaigns and was actively involved in “Saved by the beep, test your smoke alarm day” and “12 days of holiday safety”. During the year our firefighters, fire prevention staff, and ‘Sparky’® the Fire Safety Dog, our fire safety mascot, attended many other community, organization and social events, such as Halloween, Santa Claus Parades reaching thousands of community members.

Long Term Care and Group Home Facilities

The Township of North Glengarry has numerous health care and group homes that are considered vulnerable occupancies. Fire Prevention ensured that all of these facilities were completely inspected and fully in compliance with the Ontario Fire Code. Fire drills and training were also conducted at these facilities to enhance fire safety and ensure that staff complied with regulations under the Ontario Fire Code.





School Programs

Educational programs remain the most effective way to prevent fires. North Glengarry Fire Department continues to focus on a proactive approach to reducing fires by providing an assortment of fire safety education programs to students and youth. NGFD focuses on providing valuable fire safety information to selected grades partnering with Community Safety Net to provide educational Fire Life Safety resources which were distributed to selected grades at each school in our Township.

	MORE THAN	OVER
20	500	50
FIRE DRILLS	RESOURCES DISTRIBUTED	INSPECTIONS

Fire Cause and Investigations

All fires are investigated for cause and origin and when required a comprehensive investigation is completed. In 2023, investigators conducted various investigations identifying fire safety risks, preventable behaviors. Joint investigations are conducted with the Office of the Fire Marshal and other agencies to identify fire origins.



Code Enforcement

The enforcement “line of defence” is delivered primarily by the fire prevention division. This is accomplished by enforcement of various codes and performing routine fire safety complaints and inspections requests.

NGFD also conductstarget inspections based on selectedareas of risk identified within the community. The targeted inspection approach provides a proactive approach to addressing enforcement and risk.



The enforcement element addresses mandated code compliance issues, enforcing municipal by-laws, issuing orders and court action as required.

Our fire inspectors strive for voluntary compliance with the Ontario Fire Code however there are times when this is not possible. In these instances, the fire code violations are pursued in Provincial Offences Court.

Media Resources

North Glengarry Fire Department maintains a comprehensive website, with an enormous selection of fire safety and fire service information at: Fire Department - Township of North Glengarry.

North Glengarry Fire Department continues to build on its social media presence with the ongoing development of the North Glengarry Fire Department's Facebook page and Instagram account. NGFD is also actively engaged with local media ensuring timely and appropriate messages are relayed to the public.

Postings

213

Followers

1,954

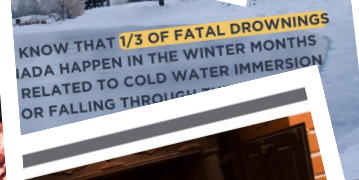
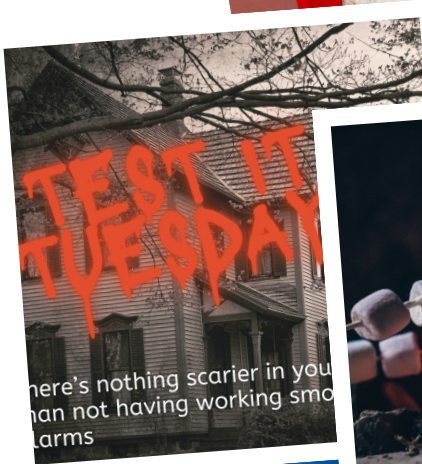

TRAINING DIVISION

The Training Division consists of Training Officers and Instructors. They work in concert with all stations of NGFD, as well as other fire services, to deliver excellent training and knowledge to our firefighters.

There were some major changes in the training requirements for NGFD personnel 2022. The Ontario Fire Marshal Office has regulated training towards NFPA standards for firefighter professional qualifications. This change now requires that all NGFD firefighters are certified to NFPA standards as set out in O/Reg 343/22 or grandfathered.

The Training Division offers a high level of training, through regular training nights at our training facility.



In 2023, through Ontario Fire College learning contracts or online learning, NGFD firefighters completed:

NFPA 1001 Firefighter I & II

NFPA 1041

NFPA 1035 Fire Life Safety Educator

NFPA 1031 Fire Inspector I

First Aid/CPR/BLS

Class A live fire

Water shuttle

Auto extrication

Ice Water Rescue.

Recruit Training

NGFD provides recruits with an in-house training program delivered through a learning contract with the Ontario Fire College NFPA 1001 Firefighter I and Firefighter II. This program must be completed, and an examination passed, before the recruits are assigned to active duty. A formal graduation ceremony is held for family and friends at the completion of the program.

SUPPRESSION DIVISION

North Glengarry Fire Department is a composite force made up of 1 career Fire Chief and 70 volunteer suppression personnel. NGFD responds to emergency incidents such as fires, motor vehicle collisions, medical assistance, and hazardous materials spills. Upon arrival at all emergency incidents, the primary response objectives are preservation of life safety, fire incident control, and property and environmental conservation. These objectives enable our suppression personnel to have clear and consistent direction during an emergency incident.

Fire suppression personnel also provide the public with fire safety education and support prevention in fire cause determination. In 2023 fire suppression personnel assisted fire prevention with the “Saved by the beep, test your smoke alarm day” program by conducting door-to-door smoke alarm inspections in defined areas of the township. They tested and ensured that working smoke alarms were on every level of the home.

For the purpose of emergency response, the North Glengarry Fire Department is divided into three districts with a total of 3 strategically located fire stations.

The following is a Township of North Glengarry Fire Department District Map:

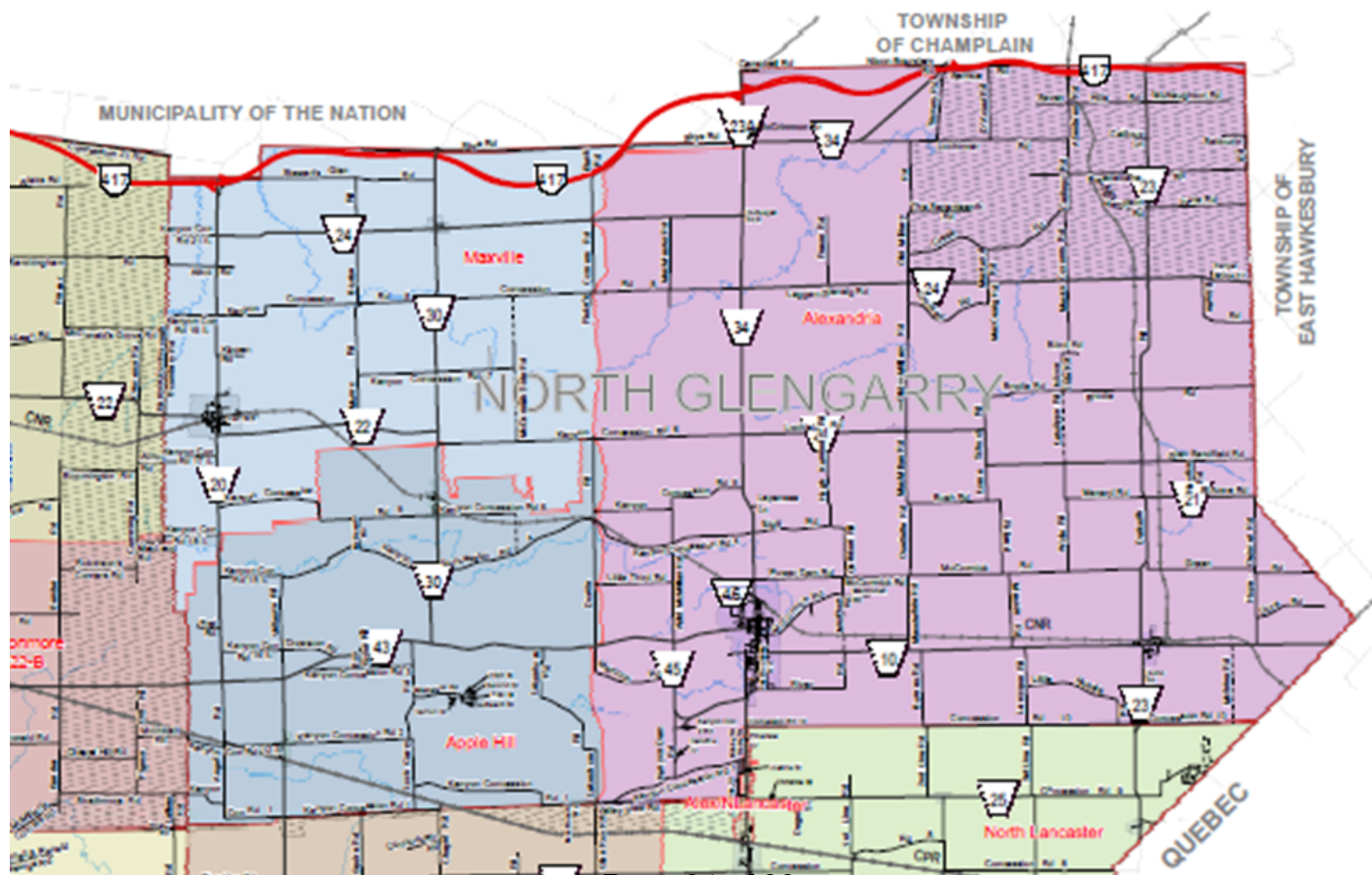

INCIDENT RESPONSES

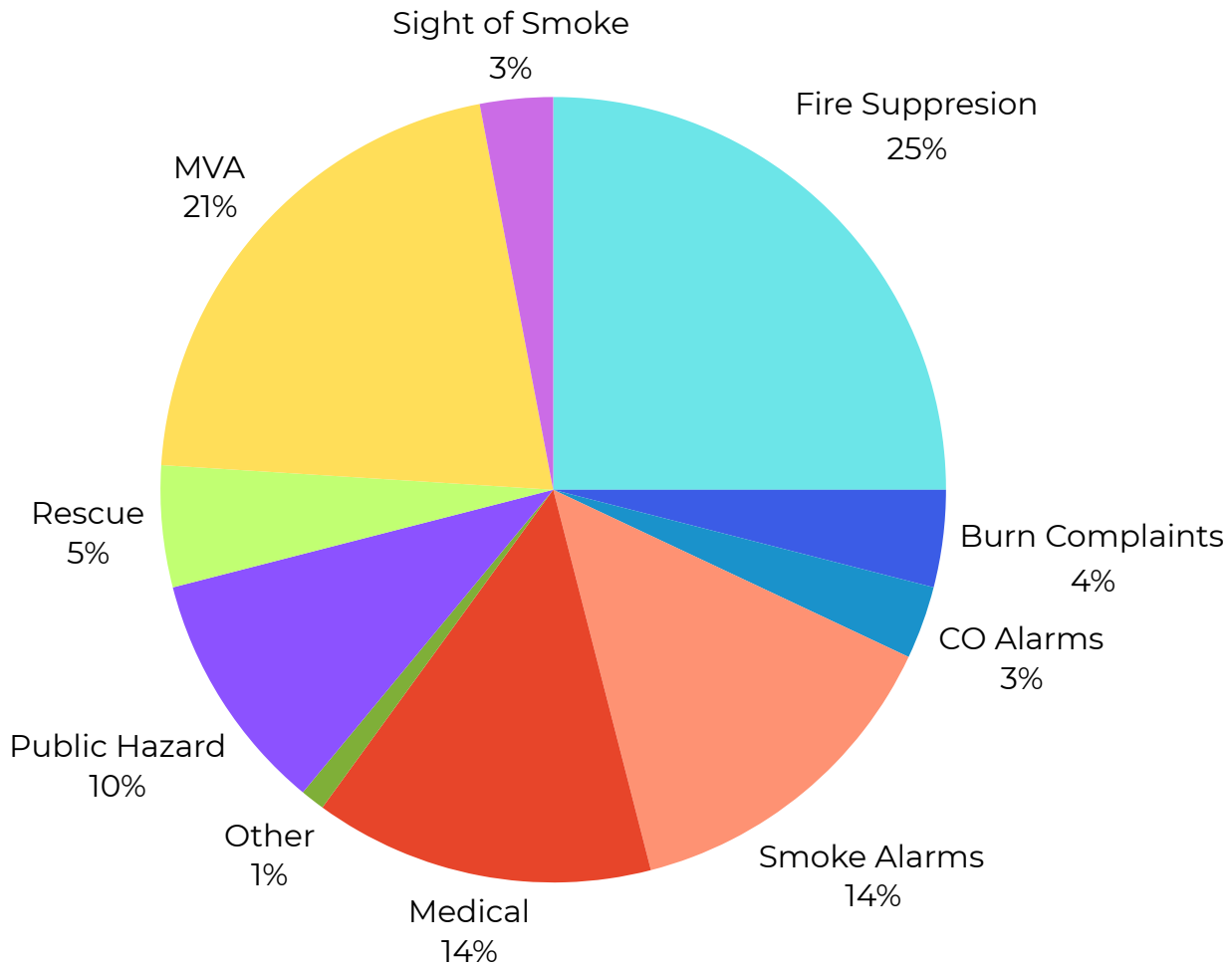

RESPONSES BY TYPE

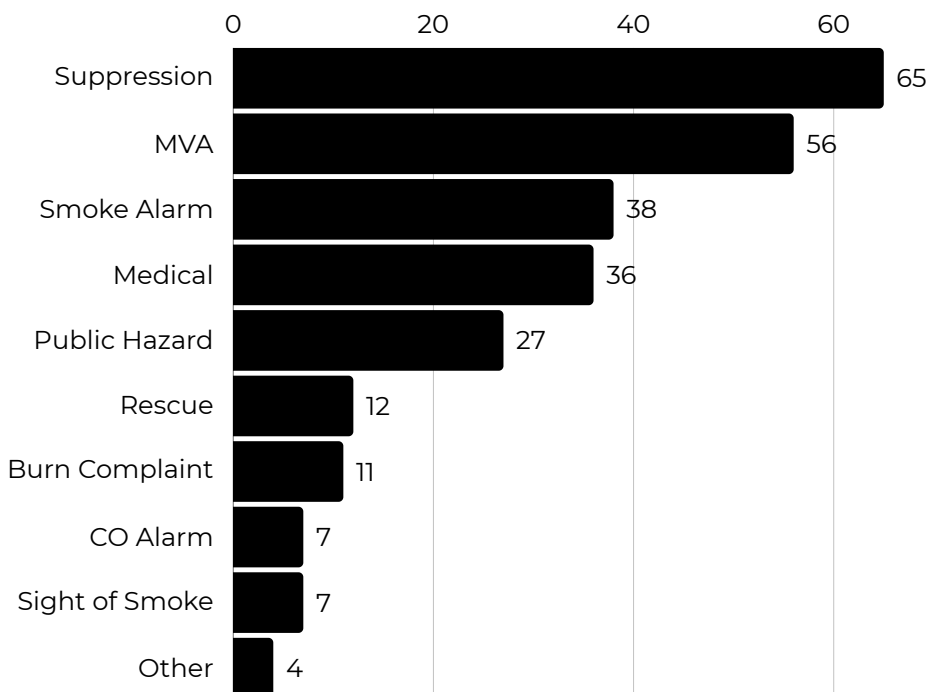

In 2023, the North Glengarry Fire Department responded to a total of **263** emergency incidents in which there were **29** structure fires with a total dollar loss of **\$3,584,702** and **no fatalities.**

INCIDENTS BY MONTH

Month	Fire Calls (structure or vehicle)	Other Fire (outdoor, rubbish)	Non-Fire	TOTAL
January	2	22	24	28
February	3	0	24	27
March	0	0	18	18
April	2	3	20	25
May	1	8	13	22
June	2	14	10	26
July	2	1	20	23
August	2	3	13	18
September	6	0	16	22
October	3	3	13	19
November	3	2	11	16
December	3	0	16	19
TOTAL CALLS	29	36	198	263

COMMUNICATION DIVISION

The North Glengarry Fire Department communication division is contracted service through the Cornwall Police Service Dispatch Centre. The Communication Centre operates a 24-hour-a-day, seven days a week, 365 days of the year service to emergency agencies. The centre is staffed with a Supervisor, full-time and part-time civilian dispatchers. Cornwall Police Communication Centre is equipped with the latest communication systems. The Computer-Aided Dispatch system interfaces with many other systems such as station alerting, digital telephone and radio recording.

The primary function of the Communications Centre is to answer emergency calls for service received from the public and maintain two-way communication with fire units responding to emergency calls using data and voice transmissions. The Communication Centre also receives and processes non-emergency calls for service.



TRAINING FACILITY

The North Glengarry Fire Department Training Facility operates in a centralized location in our Township under a lease agreement. Located at 18611 Diversion Rd, Apple Hill, the Training Facility is a unique fire training facility designed to give realistic training to firefighters.

The Training Facility officially opened in 2021, with the ability to incorporate multiple phases of expansion. As it continues to grow and develop to meet the demands and opportunities of North Glengarry Fire Department. Our next phase is to provide the opportunities for growth to external stakeholders and County Mutual Aid partners through the rental of our facility.



The closure of the Ontario Fire College, coupled with the introduction of legislation O.Reg 343/22 under the Fire Protection and Prevention Act (FPPA) requiring firefighter skillset certification outlining specific job performance requirements for firefighters, mandating training including live fire training, meant that municipalities had to adapt. Since these certifications can only be completed at training facilities with live burn capabilities, NGFD is in a good position to be able to meet the requirements at our own training facility.

This confirms that our training facility can provide the tools to prepare first responders, and external organizations for emergency response, specialized job skills and incident management techniques.

The live fire props within the training centre are designed to simulate several key types of fires. The propane live fire training props include a vehicle, assorted gas containment failures, a residential room and content fires all of which provide for skills development. The training ranges from pump operations to incident command, forcible entry, search and rescue, ventilation and fire attack to be practiced in a practical and safe environment. Combining all of the skills in a sequential, comprehensive manner is the key to be able to function efficiently and skillfully on a fire scene.

Our facility currently has a number of scenario-based training props ability to train on skills including:



Live fire burn unit:

- Class A fires
- Ventilation

Ground Fire:

- Large area to conduct ground fires.

Multi-storey complex and tower

- Fire Attack with simulated smoke
- Forcible Entry
- Roof Ladder
- Firefighter Survival Techniques
- Rapid Intervention Team



Auto extrication area:

- Training on auto extrication, in realistic conditions.
- Allow vehicles to be in a ditch, on their side or in a variety of other positions that are common occurrences when responding to collisions.

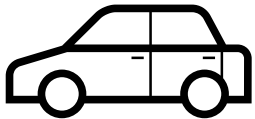

Water Site

- Pumper operations.
- Fire well drafting and water supply.



Roof Prop

- Roof ventilation techniques
- Roof Ladder deployment



Draeger Propane live car fire & LPG Cylinder prop

- Used to training on Passenger vehicle fires.
- Used to train on controlling a flammable gas cylinder fire.

